

## Wheels and castors with rubber tyres



3

## Selection tool

### Wheels and castors with rubber tyres



Series	TPA	VPP	VE	V	VWPP	VW
Category	Standard rubber					
Tread / tyre	Thermoplastic rubber-elastomer (TPE)	Standard solid rubber			Soft rubber "Blickle Soft"	
Tread and tyre hardness	85 Shore A	80 Shore A	80 Shore A	80 Shore A	50 Shore A	50 Shore A
Non-marking	✓	optional	optional	optional	optional	optional
Electrical conductivity	optional	–	optional	optional	–	–
Wheel centre / rim	polypropylene	polypropylene	pressed steel	pressed steel (impact-optimised)	polypropylene	pressed steel (impact-optimised)
Wheel Ø	80–200 mm	80–400 mm	80–200 mm	80–400 mm	125–260 mm	125–260 mm
Load capacity up to	250 kg	350 kg	205 kg	800 kg	200 kg	200 kg
Rolling resistance	■ ■ ■ ■ ■	■ ■ ■ ■ ■	■ ■ ■ ■ ■	■ ■ ■ ■ ■	■ ■ ■ ■ ■	■ ■ ■ ■ ■
Smooth operation and floor preservation	■ ■ ■ ■ ■	■ ■ ■ ■ ■	■ ■ ■ ■ ■	■ ■ ■ ■ ■	■ ■ ■ ■ ■	■ ■ ■ ■ ■
Speeds up to	4 km/h	4 km/h	4 km/h	4 km/h	4 km/h	4 km/h
For a description of the wheel, refer to	page 186	page 189–190	page 195	page 199–200	page 202	page 204
For information about swivel and fixed castors, refer to	page 187–188	page 191–194	page 196–198	page 201	page 203	page 205

■ ■ ■ ■ ■ excellent

■ ■ ■ ■ ■ very good

■ ■ ■ ■ ■ good

■ ■ ■ ■ ■ satisfactory

■ ■ ■ ■ ■ sufficient

✓ yes – no



RD	POES / ALES	POEV	ALEV	SE	GEV	DS
Premium Rubber						
Two component solid rubber "Blickle Comfort"	Elastic solid rubber "Blickle SoftMotion"	Elastic solid rubber, smooth rolling quality, "Blickle EasyRoll"			Elastic solid rubber, smooth rolling quality	
65 Shore A	55 Shore A	65 Shore A	65 Shore A	65 Shore A	65 Shore A	65 Shore A
optional	✓	optional	optional	optional	optional	–
–	–	upon request	optional	–	–	–
pressed steel (impact-optimised)	POES: nylon ALES: aluminium	nylon	aluminium	nylon (wheel Ø 80–125 mm) or pressed steel	grey cast iron	welded steel construction
100–280 mm	80–250 mm	60–300 mm	100–250 mm	80–415 mm	250–620 mm	300–500 mm
650 kg	440 kg	650 kg	650 kg	1,150 kg	4,540 kg	4,580 kg
■ ■ ■ ■ ■	■ ■ ■ ■ ■	■ ■ ■ ■ ■	■ ■ ■ ■ ■	■ ■ ■ ■ ■	■ ■ ■ ■ ■	■ ■ ■ ■ ■
■ ■ ■ ■ ■	■ ■ ■ ■ ■	■ ■ ■ ■ ■	■ ■ ■ ■ ■	■ ■ ■ ■ ■	■ ■ ■ ■ ■	■ ■ ■ ■ ■
4 km/h	POES: 4 km/h ALES: 10 km/h	4 km/h	10 km/h	10 km/h	16 km/h	16 km/h
page 206	page 209	page 212–213	page 221	page 228	page 234	page 236
page 207–208	page 210–211	page 214–220	page 222–227	page 229–233	page 235	–

## TPA series

### Wheels with thermoplastic rubber tread, with polypropylene wheel centre



100–250 kg

**Tread and tyre hardness**  
 85 Shore A

**Smooth operation / floor preservation**  
 good

**Rolling resistance**  
 very good

**Wear resistance**  
 satisfactory

3

#### Tread:

- high-quality thermoplastic rubber-elastomer (TPE), hardness 85 Shore A
- low rolling and swivel resistance
- colour grey, non-marking
- chemically-bonded inseparable connection with the wheel centre

#### Wheel centre:

- high-quality polypropylene, impact resistant
- colour silver grey ("ELS" version colour black)

#### Other features:

- KF version: with synthetic thread guard, large
- very high chemical resistance to many aggressive substances
- operating temperature: -20 °C to +60 °C, reduced load capacity over +30 °C
- tread contains oil, may stain sensitive surfaces. alternatives: series VPP, POES, POEV

#### Additional details:

- wheel series: page 60
- tread: page 52
- bearing types: page 84–85
- chemical resistance: page 51

Wheels	Wheel Ø (D) [mm]	Tyre width (T2) [mm]	Load capacity [kg]	Bearing type	Axle bore Ø (d) [mm]	Hub length (T1) [mm]
TPA 80/12G	80	32	100	plain bore	12	35
TPA 80/8KF	80	32	100	ball bearing (C)	8	36
TPA 102/12G	100	32	110	plain bore	12	45
TPA 102/8KF	100	32	110	ball bearing (C)	8	46
TPA 127/12G	125	32	125	plain bore	12	45
TPA 127/8KF	125	32	125	ball bearing (C)	8	46
TPA 160/20G	160	40	200	plain bore	20	60
TPA 160/20R	160	40	200	roller bearing	20	60
TPA 200/20G	200	40	250	plain bore	20	60
TPA 200/20R	200	40	250	roller bearing	20	60

For other dimensions, see page 122

#### Versions / options \*



	ball bearing version	electrically conductive version, non-marking grey	large thread guard with additional ball bearing seals
Technical description page		50	85
Product code suffix		-ELS	-KFD
Available for		all plain bore and ball bearing versions**	all ball bearing versions

\* Other versions / options: stainless steel roller bearing (-XR), available for all roller bearing versions (see page 84 for technical information)

\*\* Wheel load capacity of electrically conductive version reduced by 35%

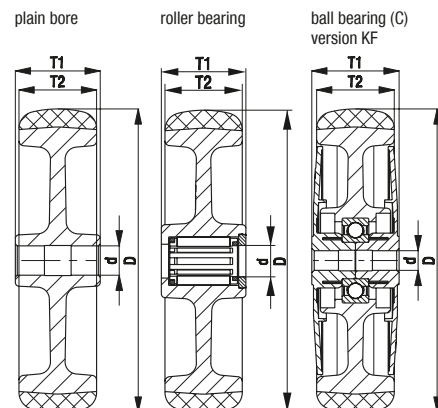

## LE-TPA, B-TPA series

**Pressed steel castors with top plate,  
wheel with thermoplastic  
rubber tread**



100–250 kg

**Bracket:** LE/B series

- pressed steel, zinc-plated, blue-passivated, Cr6-free

**Swivel bracket:**

- double ball bearing in the swivel head
- swivel head seal
- minimum swivel head play and smooth rolling characteristic and increased service life due to the special dynamic Blickle riveting process

**Wheel:** TPA series

- tread: high-quality thermoplastic rubber-elastomer (TPE), hardness 85 Shore A, colour grey, non-marking, oil containing
- wheel centre: high-quality polypropylene, impact resistant, colour silver grey ("ELS" version colour black)

**Additional details:**

- bracket series: page 90
- brakes: page 112–113
- wheel series: page 186
- bearing types: page 84–85

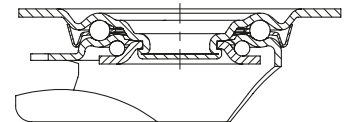

Swivel castors	Fixed castors	Swivel castors with "stop-fix" brake	Wheel Ø [mm]	Tyre width [mm]	Load capacity [kg]	Bearing type	Total height [mm]	Plate size [mm]	Bolt hole spacing [mm]	Bolt hole Ø [mm]	Offset swivel castor [mm]
LE-TPA 80G	B-TPA 80G	LE-TPA 80G-FI	80	32	100	plain bore	102	100 x 85	80 x 60	9	38
LE-TPA 80KF	B-TPA 80KF	LE-TPA 80KF-FI	80	32	100	ball bearing (C)	102	100 x 85	80 x 60	9	38
LE-TPA 102G	B-TPA 102G	LE-TPA 102G-FI	100	32	110	plain bore	125	100 x 85	80 x 60	9	36
LE-TPA 102KF	B-TPA 102KF	LE-TPA 102KF-FI	100	32	110	ball bearing (C)	125	100 x 85	80 x 60	9	36
LE-TPA 127G	B-TPA 127G	LE-TPA 127G-FI	125	32	125	plain bore	150	100 x 85	80 x 60	9	38
LE-TPA 127KF	B-TPA 127KF	LE-TPA 127KF-FI	125	32	125	ball bearing (C)	150	100 x 85	80 x 60	9	38
LE-TPA 160G	B-TPA 160G	LE-TPA 160G-FI	160	40	200	plain bore	195	140 x 110	105 x 75–80	11	54
LE-TPA 160R	B-TPA 160R	LE-TPA 160R-FI	160	40	200	roller bearing	195	140 x 110	105 x 75–80	11	54
LE-TPA 200G	B-TPA 200G	LE-TPA 200G-FI	200	40	250	plain bore	235	140 x 110	105 x 75–80	11	54
LE-TPA 200R	B-TPA 200R	LE-TPA 200R-FI	200	40	250	roller bearing	235	140 x 110	105 x 75–80	11	54

For stainless steel versions, see page 399

### Versions / options



	plain bore version	electrically conductive version, non-marking grey	large thread guard with additional ball bearing seals	with steel foot guard
Technical description page		50	85	116
<b>Product code suffix</b>		<b>-ELS</b>	<b>-KFD</b>	<b>-FS</b>
Available for		all plain bore and ball bearing versions*	all ball bearing versions	wheel Ø 100–200 mm upon request

\* Wheel load capacity of electrically conductive version reduced by 35%

## LER-TPA series

### Pressed steel castors with bolt hole, wheel with thermoplastic rubber tread

100–250 kg

**Bracket:** LER series

- pressed steel, zinc-plated, blue-passivated, Cr6-free
- double ball bearing in the swivel head
- strong central kingpin
- minimum swivel head play and smooth rolling characteristic and increased service life due to the special dynamic Blickle riveting process

**Wheel:** TPA series

- tread: high-quality thermoplastic rubber-elastomer (TPE), hardness 85 Shore A, colour grey, non-marking, oil containing
- wheel centre: high-quality polypropylene, impact resistant, colour silver grey ("ELS" version colour black)

**Additional details:**

- bracket series: page 91
- brakes: page 112–113
- wheel series: page 186
- bearing types: page 84–85



3

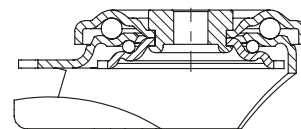

Swivel castors	Swivel castors with "stop-fix" brake	Wheel Ø [mm]	Tyre width [mm]	Load capacity [kg]	Bearing type	Total height [mm]	Plate Ø [mm]	Bolt hole Ø [mm]	Offset swivel castor [mm]
LER-TPA 80G	LER-TPA 80G-FI	80	32	100	plain bore	102	70	13	38
LER-TPA 80KF	LER-TPA 80KF-FI	80	32	100	ball bearing (C)	102	70	13	38
LER-TPA 102G	LER-TPA 102G-FI	100	32	110	plain bore	125	70	13	36
LER-TPA 102KF	LER-TPA 102KF-FI	100	32	110	ball bearing (C)	125	70	13	36
LER-TPA 127G	LER-TPA 127G-FI	125	32	125	plain bore	150	70	13	38
LER-TPA 127KF	LER-TPA 127KF-FI	125	32	125	ball bearing (C)	150	70	13	38
LER-TPA 160G	LER-TPA 160G-FI	160	40	200	plain bore	195	88	13	54
LER-TPA 160R	LER-TPA 160R-FI	160	40	200	roller bearing	195	88	13	54
LER-TPA 200G	LER-TPA 200G-FI	200	40	250	plain bore	235	88	13	54
LER-TPA 200R	LER-TPA 200R-FI	200	40	250	roller bearing	235	88	13	54

For stainless steel versions, see page 400

### Versions / options



	plain bore version	electrically conductive version, non-marking grey	large thread guard with additional ball bearing seals	with steel foot guard	truck lock
Technical description page		50	85	116	114
Product code suffix		-ELS	-KFD	-FS	FF 100-1 / FF 125-1
Available for		all plain bore and ball bearing versions*	all ball bearing versions	wheel Ø 100–200 mm upon request	wheel Ø 100+125 mm

\* Wheel load capacity of electrically conductive version reduced by 35%

VPP series, wheel Ø 80–180 mm

Wheels with standard solid rubber tyres,  
with synthetic rim

50–170 kg

**Tread and tyre hardness**

80 Shore A

**Smooth operation / floor preservation**

very good

**Rolling resistance**

satisfactory

**Wear resistance**

sufficient



3

**Tyre:**

- standard solid rubber, hardness 80 Shore A
- very good operational comfort
- very good floor preservation, low-noise operation
- colour black

**Rim:**

- high-quality polypropylene, impact resistant
- colour black

**Other features:**

- high chemical resistance to many aggressive substances, except oils
- operating temperature: -20 °C to +60 °C, reduced load capacity over +30 °C

**Additional details:**

- wheel series: page 61
- tread: page 52
- bearing types: page 84–85
- chemical resistance: page 51

Wheels	Wheel Ø (D) [mm]	Tyre width (T2) [mm]	Load capacity [kg]	Bearing type	Axle bore Ø (d) [mm]	Hub length (T1) [mm]
VPP 80/12G	80	25	50	plain bore	12	35
VPP 80/12R	80	25	50	roller bearing	12	35
VPP 100/12G	100	30	70	plain bore	12	45
VPP 100/15G	100	30	70	plain bore	15	45
VPP 100/12R	100	30	70	roller bearing	12	45
VPP 100/15R	100	30	70	roller bearing	15	45
VPP 125/12G	125	37.5	100	plain bore	12	45
VPP 125/15G	125	37.5	100	plain bore	15	45
VPP 125/12R	125	37.5	100	roller bearing	12	45
VPP 125/15R	125	37.5	100	roller bearing	15	45
VPP 140/15G	140	37.5	115	plain bore	15	45
VPP 140/15R	140	37.5	115	roller bearing	15	45
VPP 150/20G	150	40	135	plain bore	20	60
VPP 150/20R	150	40	135	roller bearing	20	60
VPP 160/20-45G	160	40	135	plain bore	20	45
VPP 160/20G	160	40	135	plain bore	20	60
VPP 160/20-45R	160	40	135	roller bearing	20	45
VPP 160/20R	160	40	135	roller bearing	20	60
VPP 180/20G	180	50	170	plain bore	20	60
VPP 180/20R	180	50	170	roller bearing	20	60

For other wheel Ø, see next page

Versions / options



	with non-marking grey tyre	with stainless steel roller bearing in the wheel hub	STARLOCK® cap made from stainless steel
Technical description page	52	84	117
Product code suffix	-SG	-XR	ST-KA 12, 15, 20
Available for	all	upon request	all axle bore Ø

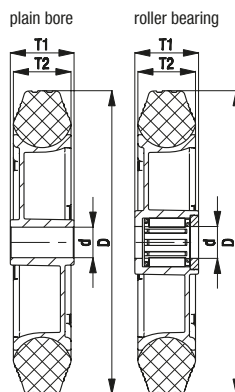

## VPP series, wheel Ø 200–400 mm

Wheels with standard solid rubber tyres,  
with synthetic rim



200–350 kg

**Tread and tyre hardness**

80 Shore A

**Smooth operation / floor preservation**

very good

**Rolling resistance**

satisfactory

**Wear resistance**

sufficient

3

**Tyre:**

- standard solid rubber, hardness 80 Shore A
- very good operational comfort
- very good floor preservation, low-noise operation
- colour black

**Rim:**

- high-quality polypropylene, impact resistant
- colour black

**Other features:**

- high chemical resistance to many aggressive substances, except oils
- operating temperature: -20 °C to +60 °C, reduced load capacity over +30 °C

**Additional details:**

- wheel series: page 61
- tread: page 52
- bearing types: page 84–85
- chemical resistance: page 51

Wheels	Wheel Ø	Tyre width	Load capacity	Bearing type	Axle bore Ø	Hub length
	(D) [mm]	(T2) [mm]	[kg]		(d) [mm]	(T1) [mm]
VPP 200/20G	200	50	205	plain bore	20	60
VPP 200/25G	200	50	205	plain bore	25	60
VPP 200/20R	200	50	205	roller bearing	20	60
VPP 200/20K	200	50	205	ball bearing	20	60
VPP 205/20G	200	65	200	plain bore	20	60
VPP 250/20G	250	60	295	plain bore	20	65
VPP 250/20-74G	250	60	295	plain bore	20	74
VPP 250/25G	250	60	295	plain bore	25	65
VPP 250/25-74G	250	60	295	plain bore	25	74
VPP 250/25R	250	60	295	roller bearing	25	65
VPP 250/20K	250	60	295	ball bearing	20	65
VPP 250/25K	250	60	295	ball bearing	25	65
VPP 254/25G	250	75	300	plain bore	25	65
VPP 256/20G	250	85	250	plain bore	20	75
VPP 256/20R	250	85	250	roller bearing	20	75
VPP 300/25G	300	60	250	plain bore	25	60
VPP 350/25R	350	75	300	roller bearing	25	75
VPP 400/25G	400	100	350	plain bore	25	75
VPP 400/25R	400	100	350	roller bearing	25	75

### Versions / options



	with non-marking grey tyre	with stainless steel roller bearing in the wheel hub	STARLOCK® cap made from stainless steel
Technical description page	52	84	117
Product code suffix	-SG	-XR	ST-KA 20, 25
Available for	wheel Ø 200x50+250x60 mm	upon request	all axle bore Ø

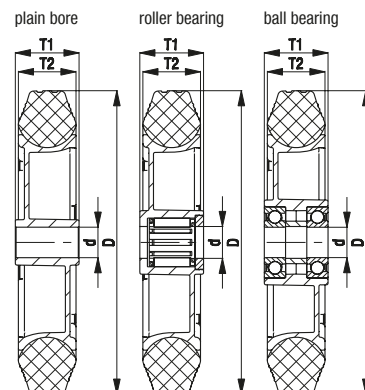



## LE-VPP, B-VPP series

### Pressed steel castors with top plate, wheel with standard solid rubber tyre

50–205 kg

**Bracket:** LE/B series

- pressed steel, zinc-plated, blue-passivated, Cr6-free

**Swivel bracket:**

- double ball bearing in the swivel head
- swivel head seal
- minimum swivel head play and smooth rolling characteristic and increased service life due to the special dynamic Blickle riveting process

**Wheel:** VPP series

- tyre: standard solid rubber, hardness 80 Shore A, colour black
- rim: high-quality polypropylene, impact resistant, colour black

**Additional details:**

- bracket series: page 90
- brakes: page 112–113
- wheel series: page 189
- bearing types: page 84–85



3

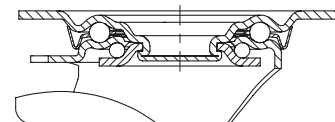

Swivel castors	Fixed castors	Swivel castors with "stop-fix" brake	Wheel Ø [mm]	Tyre width [mm]	Load capacity [kg]	Bearing type	Total height [mm]	Plate size [mm]	Bolt hole spacing [mm]	Bolt hole Ø [mm]	Offset swivel castor [mm]
LE-VPP 80G	B-VPP 80G	LE-VPP 80G-FI	80	25	50	plain bore	102	100 x 85	80 x 60	9	38
LE-VPP 80R	B-VPP 80R	LE-VPP 80R-FI	80	25	50	roller bearing	102	100 x 85	80 x 60	9	38
LE-VPP 100G	B-VPP 100G	LE-VPP 100G-FI	100	30	70	plain bore	125	100 x 85	80 x 60	9	36
LE-VPP 100R	B-VPP 100R	LE-VPP 100R-FI	100	30	70	roller bearing	125	100 x 85	80 x 60	9	36
LE-VPP 125G	B-VPP 125G	LE-VPP 125G-FI	125	37.5	100	plain bore	150	100 x 85	80 x 60	9	38
LE-VPP 125R	B-VPP 125R	LE-VPP 125R-FI	125	37.5	100	roller bearing	150	100 x 85	80 x 60	9	38
LE-VPP 150G	B-VPP 150G	LE-VPP 150G-FI	150	40	135	plain bore	190	140 x 110	105 x 75–80	11	54
LE-VPP 150R	B-VPP 150R	LE-VPP 150R-FI	150	40	135	roller bearing	190	140 x 110	105 x 75–80	11	54
LE-VPP 160G	B-VPP 160G	LE-VPP 160G-FI	160	40	135	plain bore	195	140 x 110	105 x 75–80	11	54
LE-VPP 160R	B-VPP 160R	LE-VPP 160R-FI	160	40	135	roller bearing	195	140 x 110	105 x 75–80	11	54
LE-VPP 180G	B-VPP 180G	LE-VPP 180G-FI	180	50	170	plain bore	215	140 x 110	105 x 75–80	11	50
LE-VPP 180R	B-VPP 180R	LE-VPP 180R-FI	180	50	170	roller bearing	215	140 x 110	105 x 75–80	11	50
LE-VPP 200G	B-VPP 200G	LE-VPP 200G-FI	200	50	205	plain bore	235	140 x 110	105 x 75–80	11	54
LE-VPP 200R	B-VPP 200R	LE-VPP 200R-FI	200	50	205	roller bearing	235	140 x 110	105 x 75–80	11	54

For stainless steel versions, see page 401

### Versions / options



	with non-marking grey tyre	with thread guard, pressed steel, zinc-plated	with "stop-top" brake	directional lock (separate) 1 x 360°	directional lock (separate) 1 x 360°	with steel foot guard
Technical description page	52	116	112	115	115	116
Product code suffix	-SG	-FA	-ST	RI-03.01	RI-03.03	-FS
Available for	all	all	wheel Ø 150–200 mm	wheel Ø 100–125 mm*	wheel Ø 150–200 mm*	upon request

\* Only for swivel castors without brake or swivel castor with "stop-top" brake upon request

## LER-VPP series

### Pressed steel castors with bolt hole, wheel with standard solid rubber tyre



50–205 kg

**Bracket:** LER series

- pressed steel, zinc-plated, blue-passivated, Cr6-free
- double ball bearing in the swivel head
- strong central kingpin
- minimum swivel head play and smooth rolling characteristic and increased service life due to the special dynamic Blickle riveting process

**Wheel:** VPP series

- tyre: standard solid rubber, hardness 80 Shore A, colour black
- rim: high-quality polypropylene, impact resistant, colour black

**Additional details:**

- bracket series: page 91
- brakes: page 112–113
- wheel series: page 189
- bearing types: page 84–85

3

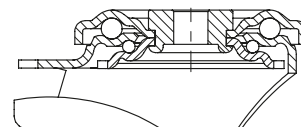

Swivel castors	Swivel castors with "stop-fix" brake	Wheel Ø [mm]	Tyre width [mm]	Load capacity [kg]	Bearing type	Total height [mm]	Plate Ø [mm]	Bolt hole Ø [mm]	Offset swivel castor [mm]
LER-VPP 80G	LER-VPP 80G-FI	80	25	50	plain bore	102	70	13	38
LER-VPP 80R	LER-VPP 80R-FI	80	25	50	roller bearing	102	70	13	38
LER-VPP 100G	LER-VPP 100G-FI	100	30	70	plain bore	125	70	13	36
LER-VPP 100R	LER-VPP 100R-FI	100	30	70	roller bearing	125	70	13	36
LER-VPP 125G	LER-VPP 125G-FI	125	37.5	100	plain bore	150	70	13	38
LER-VPP 125R	LER-VPP 125R-FI	125	37.5	100	roller bearing	150	70	13	38
LER-VPP 150G	LER-VPP 150G-FI	150	40	135	plain bore	190	88	13	54
LER-VPP 150R	LER-VPP 150R-FI	150	40	135	roller bearing	190	88	13	54
LER-VPP 160G	LER-VPP 160G-FI	160	40	135	plain bore	195	88	13	54
LER-VPP 160R	LER-VPP 160R-FI	160	40	135	roller bearing	195	88	13	54
LER-VPP 180G	LER-VPP 180G-FI	180	50	170	plain bore	215	88	13	50
LER-VPP 180R	LER-VPP 180R-FI	180	50	170	roller bearing	215	88	13	50
LER-VPP 200G	LER-VPP 200G-FI	200	50	205	plain bore	235	88	13	54
LER-VPP 200R	LER-VPP 200R-FI	200	50	205	roller bearing	235	88	13	54

For stainless steel versions, see page 402

### Versions / options



	with non-marking grey tyre	with thread guard, pressed steel, zinc-plated	with steel foot guard	truck lock
Technical description page	52	116	116	114
Product code suffix	-SG	-FA	-FS	FF 100-1 / FF 125-1
Available for	all	upon request	upon request	wheel Ø 100+125 mm

## LEZ-VPP series

### Pressed steel castors with stem, wheel with standard solid rubber tyres

50–205 kg

**Bracket:** LEZ series

- pressed steel, zinc-plated, blue-passivated, Cr6-free
- double ball bearing in the swivel head
- minimum swivel head play and smooth rolling characteristic and increased service life due to the special dynamic Blickle riveting process
- steel plug-in stem and central kingpin bolted and secured

**Wheel:** VPP series

- tyre: standard solid rubber, hardness 80 Shore A, colour black
- rim: high-quality polypropylene, impact resistant, colour black

**Additional details:**

- bracket series: page 91
- brakes: page 112–113
- wheel series: page 189
- bearing types: page 84–85

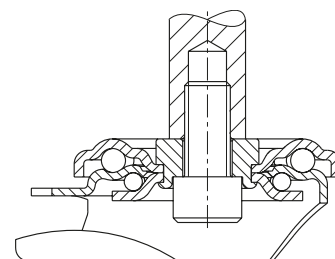

3

Swivel castors	Swivel castors with "stop-fix" brake	Wheel Ø [mm]	Tyre width [mm]	Load capacity [kg]	Bearing type	Total height [mm]	Stem Ø [mm]	Stem length [mm]	Offset swivel castor [mm]
LEZ-VPP 80G	LEZ-VPP 80G-FI	80	25	50	plain bore	102	20	50	38
LEZ-VPP 100G	LEZ-VPP 100G-FI	100	30	70	plain bore	125	20	50	36
LEZ-VPP 125G	LEZ-VPP 125G-FI	125	37.5	100	plain bore	150	20	50	38
LEZ-VPP 150G-22	LEZ-VPP 150G-22-FI	150	40	135	plain bore	190	22	60	54
LEZ-VPP 150G-27	LEZ-VPP 150G-27-FI	150	40	135	plain bore	190	27	60	54
LEZ-VPP 160G-22	LEZ-VPP 160G-22-FI	160	40	135	plain bore	195	22	60	54
LEZ-VPP 160G-27	LEZ-VPP 160G-27-FI	160	40	135	plain bore	195	27	60	54
LEZ-VPP 200G-22	LEZ-VPP 200G-22-FI	200	50	205	plain bore	235	22	60	54
LEZ-VPP 200G-27	LEZ-VPP 200G-27-FI	200	50	205	plain bore	235	27	60	54

### Versions / options



	with non-marking grey tyre	with thread guard, pressed steel, zinc-plated	with steel foot guard
Technical description page	52	116	116
Product code suffix	-SG	-FA	-FS
Available for	all	upon request	upon request

## L-VPP, B-VPP, BH-VPP series

**Pressed steel castors, medium-duty version, with top plate, wheel with standard solid rubber tyre**

50–295 kg

**Bracket:** L/B/BH series

- pressed steel, zinc-plated, blue-passivated, Cr6-free

**Swivel bracket:**

- double ball bearing in the swivel head
- strong central kingpin (from wheel Ø 150 mm)
- swivel head seal
- minimum swivel head play and smooth rolling characteristic and increased service life due to the special dynamic Blickle riveting process

**Wheel:** VPP series

- tyre: standard solid rubber, hardness 80 Shore A, colour black
- rim: high-quality polypropylene, impact resistant, colour black

**Additional details:**

- bracket series: page 91
- brakes: page 112–113
- wheel series: page 189
- bearing types: page 84–85



3

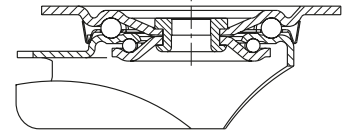

Swivel castors	Fixed castors	Swivel castors with "stop-fix" brake	Wheel Ø [mm]	Tyre width [mm]	Load capacity [kg]	Bearing type	Total height [mm]	Plate size [mm]	Bolt hole spacing [mm]	Bolt hole Ø [mm]	Offset swivel castor [mm]
L-VPP 80G	B-VPP 80G	L-VPP 80G-FI	80	25	50	plain bore	102	100 x 85	80 x 60	9	38
L-VPP 80R	B-VPP 80R	L-VPP 80R-FI	80	25	50	roller bearing	102	100 x 85	80 x 60	9	38
L-VPP 100G	B-VPP 100G	L-VPP 100G-FI	100	30	70	plain bore	125	100 x 85	80 x 60	9	36
L-VPP 100R	B-VPP 100R	L-VPP 100R-FI	100	30	70	roller bearing	125	100 x 85	80 x 60	9	36
L-VPP 125G	B-VPP 125G	L-VPP 125G-FI	125	37.5	100	plain bore	150	100 x 85	80 x 60	9	38
L-VPP 125R	B-VPP 125R	L-VPP 125R-FI	125	37.5	100	roller bearing	150	100 x 85	80 x 60	9	38
L-VPP 140G	B-VPP 140G	L-VPP 140G-FI	140	37.5	115	plain bore	170	140 x 110	105 x 75–80	11	50
L-VPP 140R	B-VPP 140R	L-VPP 140R-FI	140	37.5	115	roller bearing	170	140 x 110	105 x 75–80	11	50
L-VPP 160G	B-VPP 160G	L-VPP 160G-FI	160	40	135	plain bore	195	140 x 110	105 x 75–80	11	60
L-VPP 160R	B-VPP 160R	L-VPP 160R-FI	160	40	135	roller bearing	195	140 x 110	105 x 75–80	11	60
L-VPP 180G	B-VPP 180G	L-VPP 180G-FI	180	50	170	plain bore	215	140 x 110	105 x 75–80	11	60
L-VPP 180R	B-VPP 180R	L-VPP 180R-FI	180	50	170	roller bearing	215	140 x 110	105 x 75–80	11	60
L-VPP 200G	B-VPP 200G	L-VPP 200G-FI	200	50	205	plain bore	235	140 x 110	105 x 75–80	11	65
L-VPP 200R	B-VPP 200R	L-VPP 200R-FI	200	50	205	roller bearing	235	140 x 110	105 x 75–80	11	65
L-VPP 250G-3	BH-VPP 250G	*	250	60	295	plain bore	295	140 x 110	105 x 75–80	11	77
L-VPP 250R-3	BH-VPP 250R	*	250	60	295	roller bearing	295	140 x 110	105 x 75–80	11	77

\* "stop-top" brake version, see versions / options

### Versions / options



	with non-marking grey tyre	with thread guard, pressed steel, zinc-plated	with "stop-top" brake	directional lock (separate) 1 x 360°	directional lock (separate) 1 x 360°	with steel foot guard
Technical description page	52	116	112	115	115	116
<b>Product code suffix</b>	<b>-SG</b>	<b>-FA</b>	<b>-ST</b>	<b>RI-03.01</b>	<b>RI-05.03</b>	<b>-FS</b>
Available for	all	wheel Ø 80–200 mm	all	wheel Ø 100–125 mm**	wheel Ø 160–200 mm**	upon request

\*\* Only for swivel castors without brake or swivel castor with "stop-top" brake upon request

## VE series

Wheels with standard solid rubber tyre,  
with pressed steel rim

50–205 kg

### Tread and tyre hardness

80 Shore A

### Smooth operation / floor preservation

very good

### Rolling resistance

satisfactory

### Wear resistance

sufficient



3

### Tyre:

- standard solid rubber, hardness 80 Shore A
- very good operational comfort
- very good floor preservation, low-noise operation
- colour black

### Rim:

- pressed steel
- zinc-plated, blue-passivated, Cr6-free

### Other features:

- chemical resistance to many aggressive substances, except oils
- operating temperature: -25 °C to +80 °C, reduced load capacity over +60 °C

### Additional details:

- wheel series: page 61
- tread: page 52
- bearing types: page 84–85
- chemical resistance: page 51

Wheels	Wheel Ø (D) [mm]	Tyre width (T2) [mm]	Load capacity [kg]	Bearing type	Axle bore Ø (d) [mm]	Hub length (T1) [mm]
VE 80/12R	80	25	50	roller bearing	12	35
VE 100/12R	100	30	70	roller bearing	12	45
VE 125/12R	125	37.5	100	roller bearing	12	45
VE 150/20R	150	40	135	roller bearing	20	60
VE 160/20R	160	40	135	roller bearing	20	60
VE 180/20R	180	50	170	roller bearing	20	60
VE 200/20R	200	50	205	roller bearing	20	60

For other dimensions, see wheel series V on page 199, 200

## Versions / options



	with non-marking grey tyre	electrically conductive version, black tyre
Technical description page	52	50
Product code suffix	-SG	-EL
Available for	all	all

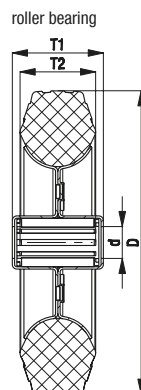

## LE-VE, B-VE series

### Pressed steel castors with top plate, wheel with standard solid rubber tyre

50–205 kg

**Bracket:** LE/B series

- pressed steel, zinc-plated, blue-passivated, Cr6-free

**Swivel bracket:**

- double ball bearing in the swivel head
- swivel head seal
- minimum swivel head play and smooth rolling characteristic and increased service life due to the special dynamic Blickle riveting process

**Wheel:** VE series

- tyre: standard solid rubber, hardness 80 Shore A, colour black
- rim: pressed steel, zinc-plated, blue-passivated, Cr6-free

**Additional details:**

- bracket series: page 90
- brakes: page 112–113
- wheel series: page 195
- bearing types: page 84–85



3

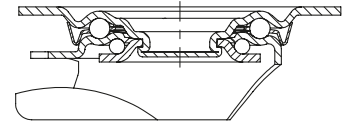

Swivel castors	Fixed castors	Swivel castors with "stop-fix" brake	Wheel Ø [mm]	Tyre width [mm]	Load capacity [kg]	Bearing type	Total height [mm]	Plate size [mm]	Bolt hole spacing [mm]	Bolt hole Ø [mm]	Offset swivel castor [mm]
LE-VE 80R	B-VE 80R	LE-VE 80R-FI	80	25	50	roller bearing	102	100 x 85	80 x 60	9	38
LE-VE 100R	B-VE 100R	LE-VE 100R-FI	100	30	70	roller bearing	125	100 x 85	80 x 60	9	36
LE-VE 125R	B-VE 125R	LE-VE 125R-FI	125	37.5	100	roller bearing	150	100 x 85	80 x 60	9	38
LE-VE 150R	B-VE 150R	LE-VE 150R-FI	150	40	135	roller bearing	190	140 x 110	105 x 75–80	11	54
LE-VE 160R	B-VE 160R	LE-VE 160R-FI	160	40	135	roller bearing	195	140 x 110	105 x 75–80	11	54
LE-VE 180R	B-VE 180R	LE-VE 180R-FI	180	50	170	roller bearing	215	140 x 110	105 x 75–80	11	50
LE-VE 200R	B-VE 200R	LE-VE 200R-FI	200	50	205	roller bearing	235	140 x 110	105 x 75–80	11	54

### Versions / options



	with non-marking grey tyre	electrically conductive version, black tyre	with thread guard, pressed steel, zinc-plated	with "stop-top" brake	with "central-stop" central brake system	directional lock (separate) 1 x 360°	with steel foot guard
Technical description page	52	50	116	112	113	115	116
<b>Product code suffix</b>	<b>-SG</b>	<b>-EL</b>	<b>-FA</b>	<b>-ST</b>	<b>-CS11</b>	<b>RI-03.01 / RI-03.03</b>	<b>-FS</b>
Available for	all	all	all	wheel Ø 150–200 mm	wheel Ø 160+200 mm	RI-03.01: Ø 100–125 RI-03.03: Ø 150–200 *	from wheel Ø 100 mm upon request

\* Only for swivel castors without brake or swivel castor with "stop-top" and "central-stop" brake upon request

## LER-VE series

### Pressed steel castors with bolt hole, wheel with standard solid rubber tyre



50–205 kg

**Bracket:** LER series

- pressed steel, zinc-plated, blue-passivated, Cr6-free
- double ball bearing in the swivel head
- strong central kingpin
- minimum swivel head play and smooth rolling characteristic and increased service life due to the special dynamic Blickle riveting process

**Wheel:** VE series

- tyre: standard solid rubber, hardness 80 Shore A, colour black
- rim: pressed steel, zinc-plated, blue-passivated, Cr6-free

**Additional details:**

- bracket series: page 91
- brakes: page 112–113
- wheel series: page 195
- bearing types: page 84–85

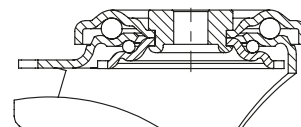

Swivel castors	Swivel castors with "stop-fix" brake	Wheel Ø [mm]	Tyre width [mm]	Load capacity [kg]	Bearing type	Total height [mm]	Plate Ø [mm]	Bolt hole Ø [mm]	Offset swivel castor [mm]
LER-VE 80R	LER-VE 80R-FI	80	25	50	roller bearing	102	70	13	38
LER-VE 100R	LER-VE 100R-FI	100	30	70	roller bearing	125	70	13	36
LER-VE 125R	LER-VE 125R-FI	125	37.5	100	roller bearing	150	70	13	38
LER-VE 150R	LER-VE 150R-FI	150	40	135	roller bearing	190	88	13	54
LER-VE 160R	LER-VE 160R-FI	160	40	135	roller bearing	195	88	13	54
LER-VE 180R	LER-VE 180R-FI	180	50	170	roller bearing	215	88	13	50
LER-VE 200R	LER-VE 200R-FI	200	50	205	roller bearing	235	88	13	54

### Versions / options



	with non-marking grey tyre	electrically conductive version, black tyre	with thread guard, pressed steel, zinc-plated	with steel foot guard	truck lock
Technical description page	52	50	116	116	114
Product code suffix	-SG	-EL	-FA	-FS	FF 100-1 / FF 125-1
Available for	all	all	all	upon request	wheel Ø 100+125 mm

## LEZ-VE series

### Pressed steel castors with stem, wheel with standard solid rubber tyres



50–205 kg

**Bracket:** LEZ series

- pressed steel, zinc-plated, blue-passivated, Cr6-free
- double ball bearing in the swivel head
- minimum swivel head play and smooth rolling characteristic and increased service life due to the special dynamic Blickle riveting process
- steel plug-in stem and central kingpin bolted and secured

**Wheel:** VE series

- tyre: standard solid rubber, hardness 80 Shore A, colour black
- rim: pressed steel, zinc-plated, blue-passivated, Cr6-free

**Additional details:**

- bracket series: page 91
- brakes: page 112–113
- wheel series: page 195
- bearing types: page 84–85

3

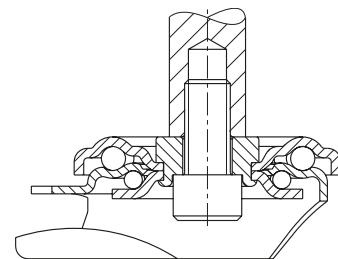

Swivel castors	Swivel castors with "stop-fix" brake	Wheel Ø [mm]	Tyre width [mm]	Load capacity [kg]	Bearing type	Total height [mm]	Stem Ø [mm]	Stem length [mm]	Offset swivel castor [mm]
LEZ-VE 80R	LEZ-VE 80R-FI	80	25	50	roller bearing	102	20	50	38
LEZ-VE 100R	LEZ-VE 100R-FI	100	30	70	roller bearing	125	20	50	36
LEZ-VE 125R	LEZ-VE 125R-FI	125	37.5	100	roller bearing	150	20	50	38
LEZ-VE 150R-22	LEZ-VE 150R-22-FI	150	40	135	roller bearing	190	22	60	54
LEZ-VE 150R-27	LEZ-VE 150R-27-FI	150	40	135	roller bearing	190	27	60	54
LEZ-VE 160R-22	LEZ-VE 160R-22-FI	160	40	135	roller bearing	195	22	60	54
LEZ-VE 160R-27	LEZ-VE 160R-27-FI	160	40	135	roller bearing	195	27	60	54
LEZ-VE 180R-22	LEZ-VE 180R-22-FI	180	50	170	roller bearing	215	22	60	50
LEZ-VE 180R-27	LEZ-VE 180R-27-FI	180	50	170	roller bearing	215	27	60	50
LEZ-VE 200R-22	LEZ-VE 200R-22-FI	200	50	205	roller bearing	235	22	60	54
LEZ-VE 200R-27	LEZ-VE 200R-27-FI	200	50	205	roller bearing	235	27	60	54

### Versions / options



	with non-marking grey tyre	electrically conductive version, black tyre	with steel foot guard	with thread guard, pressed steel, zinc-plated
Technical description page	52	50	116	116
<b>Product code suffix</b>	<b>-SG</b>	<b>-EL</b>	<b>-FS</b>	<b>-FA</b>
Available for	all	all	upon request	upon request



## V series, wheel Ø 80–200 mm

**Wheels with standard solid rubber tyre,  
with pressed steel rim,  
reinforced version**

50–300 kg

**Tread and tyre hardness**

80 Shore A

**Smooth operation / floor preservation**

very good

**Rolling resistance**

satisfactory

**Wear resistance**

sufficient



3

**Tyre:**

- standard solid rubber, hardness 80 Shore A
- very good operational comfort
- very good floor preservation, low-noise operation
- colour black

**Rim:**

- pressed steel
- strong rim structure with tubular steel hub, bolted or pressed
- zinc-plated, blue-passivated, Cr6-free

**Other features:**

- chemical resistance to many aggressive substances, except oils
- operating temperature: -20 °C to +80 °C, reduced load capacity over +60 °C

**Additional details:**

- wheel series: page 62
- tread: page 52
- bearing types: page 84–85
- chemical resistance: page 51

Wheels	Wheel Ø (D) [mm]	Tyre width (T2) [mm]	Load capacity [kg]	Bearing type	Axle bore Ø (d) [mm]	Hub length (T1) [mm]
V 80/12R	80	25	50	roller bearing	12	35
V 100/15R	100	30	70	roller bearing	15	45
V 125/15R	125	37.5	100	roller bearing	15	45
V 140/15R	140	37.5	115	roller bearing	15	45
V 162/20G	160	40	135	plain bore	20	60
V 162/20R	160	40	135	roller bearing	20	60
V 182/20G	180	50	170	plain bore	20	60
V 182/20R	180	50	170	roller bearing	20	60
V 184/20-50K *	180	80	300	ball bearing	20	50
V 202/20G	200	50	205	plain bore	20	60
V 202/20R	200	50	205	roller bearing	20	60
V 202/25R	200	50	205	roller bearing	25	60
V 200/20K *	200	50	205	ball bearing	20	60
V 205/20R	200	65	225	roller bearing	20	60

\* Bolted version

For other wheel Ø, see next page

### Versions / options



image	with non-marking grey tyre	electrically conductive version, black tyre
V 184/20-50K		
Technical description page	52	50
Product code suffix	-SG	-EL
Available for	wheel Ø 80–180x50, 200x50 mm**	wheel Ø 80–180x50, 200x50 mm**

\*\* Only for roller bearings and ball bearings

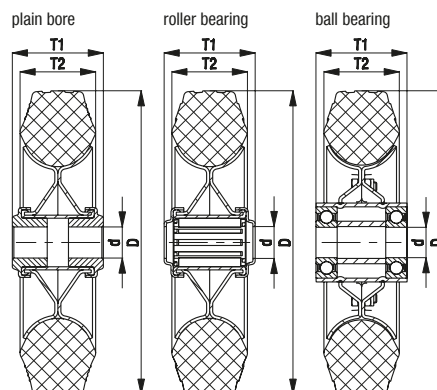

## V series, wheel Ø 250–400 mm

**Wheels with standard solid rubber tyre,  
with pressed steel rim,  
reinforced version**

295–800 kg

**Tread and tyre hardness**

80 Shore A

**Smooth operation / floor preservation**

very good

**Rolling resistance**

satisfactory

**Wear resistance**

sufficient



3

**Tyre:**

- standard solid rubber, hardness 80 Shore A
- very good operational comfort
- very good floor preservation, low-noise operation
- colour black

**Rim:**

- pressed steel
- strong rim structure with tubular steel hub, bolted or pressed
- zinc-plated, blue-passivated, Cr6-free

**Other features:**

- chemical resistance to many aggressive substances, except oils
- operating temperature: -20 °C to +80 °C, reduced load capacity over +60 °C

**Additional details:**

- wheel series: page 62
- tread: page 52
- bearing types: page 84–85
- chemical resistance: page 51

Wheels	Wheel Ø	Tyre width	Load capacity	Bearing type	Axle bore Ø	Hub length
	(D) [mm]	(T2) [mm]	[kg]		(d) [mm]	(T1) [mm]
V 252/20G *	250	60	295	plain bore	20	65
V 252/25G *	250	60	295	plain bore	25	65
V 252/25R *	250	60	295	roller bearing	25	65
V 250/25K	250	60	295	ball bearing	25	65
V 254/25-65R	250	75	320	roller bearing	25	65
V 256/20-75K	250	85	350	ball bearing	20	75
V 256/25-75K	250	85	350	ball bearing	25	75
V 265/25-75G	265	64	800 **	plain bore	25	75
V 282/25R *	280	70	385	roller bearing	25	75
V 302/30-55G	300	60	700 **	plain bore	30	55
V 302/25-50R	300	60	300	roller bearing	25	50
V 302/25-75R	300	60	300	roller bearing	25	75
V 350/25-80R	350	70	300	roller bearing	25	80
V 350/25-75K	350	70	300	ball bearing	25	75
V 400/25-90G	400	75	300	plain bore	25	90
V 400/25-75R	400	75	300	roller bearing	25	75
V 400/25-90R	400	75	300	roller bearing	25	90
V 400/30-90R	400	75	300	roller bearing	30	90
V 402/25-90R	400	80	475	roller bearing	25	90
V 402/30-90K	400	80	475	ball bearing	30	90

\* Centrally-pressed version

\*\* Support load

### Versions / options



	with non-marking grey tyre	electrically conductive version, black tyre
Technical description page	52	50
Product code suffix	-SG	-EL
Available for	wheel Ø 250x60 mm***	wheel Ø 250x60 mm***

\*\*\* Only for roller bearings and ball bearings

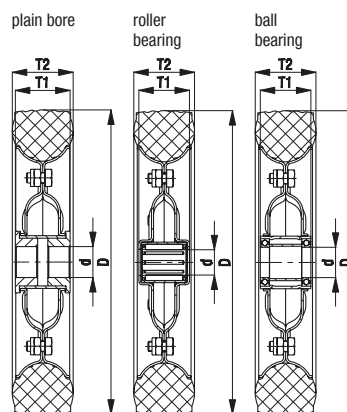

## L-V, B-V, BH-V series

**Pressed steel castors, medium-duty version, with top plate, wheel with standard solid rubber tyre**

50–385 kg



**Bracket:** L/B/BH series

- pressed steel, zinc-plated, blue-passivated, Cr6-free

**Swivel bracket:**

- double ball bearing in the swivel head
- strong central kingpin (from wheel Ø 150 mm)
- swivel head seal (exception: plate size 175x175 mm)
- minimum swivel head play and smooth rolling characteristic and increased service life due to the special dynamic Blickle riveting process

**Wheel:** V series

- tyre: standard solid rubber, hardness 80 Shore A, colour black
- rim: pressed steel, strong rim structure with tubular steel hub, bolted or pressed, zinc-plated, blue-passivated, Cr6-free

**Additional details:**

- bracket series: page 91
- brakes: page 112–113
- wheel series: page 199
- bearing types: page 84–85

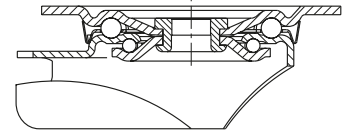

Swivel castors	Fixed castors	Swivel castors with "stop-fix" brake	Wheel Ø [mm]	Tyre width [mm]	Load capacity [kg]	Bearing type	Total height [mm]	Plate size [mm]	Bolt hole spacing [mm]	Bolt hole Ø [mm]	Offset swivel castor [mm]
L-V 80R	B-V 80R	L-V 80R-FI	80	25	50	roller bearing	102	100 x 85	80 x 60	9	38
L-V 100R	B-V 100R	L-V 100R-FI	100	30	70	roller bearing	125	100 x 85	80 x 60	9	36
L-V 125R	B-V 125R	L-V 125R-FI	125	37.5	100	roller bearing	150	100 x 85	80 x 60	9	38
L-V 140R	B-V 140R	L-V 140R-FI	140	37.5	115	roller bearing	170	140 x 110	105 x 75–80	11	50
L-V 162R	B-V 162R	L-V 162R-FI	160	40	135	roller bearing	195	140 x 110	105 x 75–80	11	60
L-V 182R	B-V 182R	L-V 182R-FI	180	50	170	roller bearing	215	140 x 110	105 x 75–80	11	60
L-V 202R	B-V 202R	L-V 202R-FI	200	50	205	roller bearing	235	140 x 110	105 x 75–80	11	65
L-V 200K	B-V 200K	L-V 200K-FI	200	50	205	ball bearing	235	140 x 110	105 x 75–80	11	65
L-V 205R	B-V 205R	*	200	65	225	roller bearing	240	140 x 110	105 x 75–80	11	70
L-V 252R-3	BH-V 252R	*	250	60	295	roller bearing	295	140 x 110	105 x 75–80	11	77
L-V 252R		*	250	60	295	roller bearing	295	175 x 175	140 x 140	15	70
	B-V 252R		250	60	295	roller bearing	295	220 x 130	190 x 75	15	–
L-V 256K		*	250	85	350	ball bearing	295	175 x 175	140 x 140	15	70
	B-V 256K		250	85	350	ball bearing	295	220 x 130	190 x 75	15	–
L-V 282R		*	280	70	385	roller bearing	318	175 x 175	140 x 140	15	78
	B-V 282R		280	70	385	roller bearing	318	220 x 130	190 x 75	15	–

\* "stop-top" brake version, see versions / options

### Versions / options



	with non-marking grey tyre	electrically conductive version, black tyre	with thread guard, pressed steel, zinc-plated	with "stop-top" brake	directional lock (separate) 1 x 360°	with steel foot guard
Technical description page	52	50	116	112	115	116
<b>Product code suffix</b>	<b>-SG</b>	<b>-EL</b>	<b>-FA</b>	<b>-ST</b>	<b>RI-03.01 / RI-05.03</b>	<b>-FS</b>
Available for	wheel Ø 80–200x50, 250x60 mm	wheel Ø 80–200x50, 250x60 mm	wheel Ø 80–250x60 mm	all	RI-03.01: Ø 100–125 RI-05.03: Ø 160–200x50 **	wheel Ø 100–250 mm upon request

\*\* Only for swivel castors without brake or swivel castor with "stop-top" brake upon request

## VWPP series

Wheels with “Blickle Soft” soft rubber tyres,  
with synthetic rim



50–200 kg

**Tread and tyre hardness**

50 Shore A

**Smooth operation / floor preservation**

excellent

**Rolling resistance**

good

**Wear resistance**

satisfactory



3

**Tyre:**

- soft rubber “Blickle Soft”, highly elastic, round profile, hardness 50 Shore A
- maximum operational comfort
- excellent floor preservation, particularly quiet operation
- colour black

**Rim:**

- high-quality polypropylene, impact resistant
- colour black

**Other features:**

- high chemical resistance to many aggressive substances, except oils
- operating temperature: -20 °C to +60 °C, reduced load capacity over +30 °C
- wheel Ø 260 mm with additional hard rubber core
- puncture-proof alternatives for pneumatic tyres

**Additional details:**

- wheel series: page 62
- tread: page 52
- bearing types: page 84–85
- chemical resistance: page 51

Wheels	Wheel Ø	Tyre width	Load capacity	Bearing type	Axle bore Ø	Hub length
	(D) [mm]	(T2) [mm]	[kg]		(d) [mm]	(T1) [mm]
VWPP 125/12G	125	37.5	50	plain bore	12	45
VWPP 125/12R	125	37.5	50	roller bearing	12	45
VWPP 160/20G	160	40	70	plain bore	20	60
VWPP 160/20R	160	40	70	roller bearing	20	60
VWPP 200/20G	200	50	100	plain bore	20	60
VWPP 200/20R	200	50	100	roller bearing	20	60
VWPP 250/25G	250	60	160	plain bore	25	65
VWPP 250/25R	250	60	160	roller bearing	25	65
VWPP 260/20G	260	85	200	plain bore	20	75
VWPP 260/20R	260	85	200	roller bearing	20	75
VWPP 260/20K	260	85	200	ball bearing	20	75

### Versions / options



image	with non-marking grey tyre	with stainless steel roller bearing in the wheel hub
VWPP 260/20K		
Technical description page	52	84
<b>Product code suffix</b>	<b>-SG</b>	<b>-XR</b>
Available for	wheel Ø 125–200 mm, others upon request	upon request

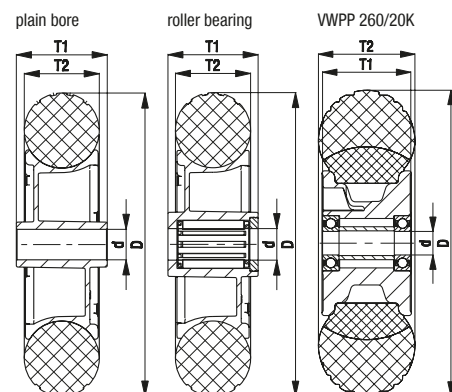

## L-VWPP, B-VWPP, BH-VWPP series

Pressed steel castors, medium-duty version, with top plate, wheel with "Blickle Soft" soft rubber tyre



50–200 kg

**Bracket:** L/B/BH series

- pressed steel, zinc-plated, blue-passivated, Cr6-free

**Swivel bracket:**

- double ball bearing in the swivel head
- strong central kingpin (from wheel Ø 150 mm)
- swivel head seal (exception: plate size 175x175 mm)
- minimum swivel head play and smooth rolling characteristic and increased service life due to the special dynamic Blickle riveting process

**Wheel:** VWPP series

- tyre: soft rubber "Blickle Soft", hardness 50 Shore A, colour black (wheel Ø 260 mm with additional hard rubber core)
- rim: high-quality polypropylene, impact resistant, colour black

**Additional details:**

- bracket series: page 91
- brakes: page 112–113
- wheel series: page 202
- bearing types: page 84–85

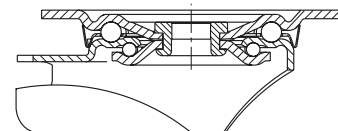

Swivel castors	Fixed castors	Swivel castors with "stop-fix" brake	Wheel Ø [mm]	Tyre width [mm]	Load capacity [kg]	Bearing type	Total height [mm]	Plate size [mm]	Bolt hole spacing [mm]	Bolt hole Ø [mm]	Offset swivel castor [mm]
L-VWPP 125G	B-VWPP 125G	L-VWPP 125G-FI	125	37.5	50	plain bore	150	100 x 85	80 x 60	9	38
L-VWPP 125R	B-VWPP 125R	L-VWPP 125R-FI	125	37.5	50	roller bearing	150	100 x 85	80 x 60	9	38
L-VWPP 160G	B-VWPP 160G	L-VWPP 160G-FI	160	40	70	plain bore	195	140 x 110	105 x 75–80	11	60
L-VWPP 160R	B-VWPP 160R	L-VWPP 160R-FI	160	40	70	roller bearing	195	140 x 110	105 x 75–80	11	60
L-VWPP 200G	B-VWPP 200G	L-VWPP 200G-FI	200	50	100	plain bore	235	140 x 110	105 x 75–80	11	65
L-VWPP 200R	B-VWPP 200R	L-VWPP 200R-FI	200	50	100	roller bearing	235	140 x 110	105 x 75–80	11	65
L-VWPP 250G-3	BH-VWPP 250G	*	250	60	160	plain bore	295	140 x 110	105 x 75–80	11	77
L-VWPP 250R-3	BH-VWPP 250R	*	250	60	160	roller bearing	295	140 x 110	105 x 75–80	11	77
L-VWPP 260G		*	260	85	200	plain bore	308	175 x 175	140 x 140	15	78
	B-VWPP 260G		260	85	200	plain bore	308	220 x 130	190 x 75	15	–
L-VWPP 260R		*	260	85	200	roller bearing	308	175 x 175	140 x 140	15	78
	B-VWPP 260R		260	85	200	roller bearing	308	220 x 130	190 x 75	15	–
L-VWPP 260K		*	260	85	200	ball bearing	308	175 x 175	140 x 140	15	78
	B-VWPP 260K		260	85	200	ball bearing	308	220 x 130	190 x 75	15	–

\* "stop-top" brake version, see versions / options

### Versions / options



	with non-marking grey tyre	with thread guard, pressed steel, zinc-plated	with "stop-top" brake	directional lock (separate) 1 x 360°	directional lock (separate) 1 x 360°	with stainless steel roller bearing in the wheel hub	with steel foot guard
Technical description page	52	116	112	115	115	84	116
Product code suffix	-SG	-FA	-ST	RI-03.01	RI-05.03	-XR	-FS
Available for	wheel Ø 125–200 mm, others upon request	wheel Ø 125–200 mm	all	wheel Ø 125 mm**	wheel Ø 160–200 mm**	upon request	up to wheel Ø 250 mm upon request

\*\* Only for swivel castors without brake or swivel castor with "stop-top" brake upon request

## VW series

Wheels with “Blickle Soft” soft rubber tyres,  
with pressed steel rim



50–200 kg

**Tread and tyre hardness**

50 Shore A

**Smooth operation / floor preservation**

excellent

**Rolling resistance**

good

**Wear resistance**

satisfactory



3

**Tyre:**

- soft rubber “Blickle Soft”, highly elastic, round profile, hardness 50 Shore A
- maximum operational comfort
- excellent floor preservation, particularly quiet operation
- colour black

**Rim:**

- pressed steel
- strong rim structure with tubular steel hub, bolted or pressed
- zinc-plated, blue-passivated, Cr6-free

**Other features:**

- chemical resistance to many aggressive substances, except oils
- operating temperature: -20 °C to +80 °C, reduced load capacity over +60 °C
- wheel Ø 260 mm with additional hard rubber core
- puncture-proof alternatives for pneumatic tyres

**Additional details:**

- wheel series: page 62
- tread: page 52
- bearing types: page 84–85
- chemical resistance: page 51

Wheels	Wheel Ø (D) [mm]	Tyre width (T2) [mm]	Load capacity [kg]	Bearing type	Axle bore Ø (d) [mm]	Hub length (T1) [mm]
VW 125/15R	125	37.5	50	roller bearing	15	45
VW 162/20R	160	40	70	roller bearing	20	60
VW 202/20R	200	50	100	roller bearing	20	60
VW 252/25R	250	60	160	roller bearing	25	65
VW 260/20R *	260	85	200	roller bearing	20	75
VW 260/20K *	260	85	200	ball bearing	20	75

\* Bolted version

### Versions / options



image VW 260/20K	with non-marking grey tyre
Technical description page	52
Product code suffix	-SG
Available for	wheel Ø 125–200 mm, others upon request

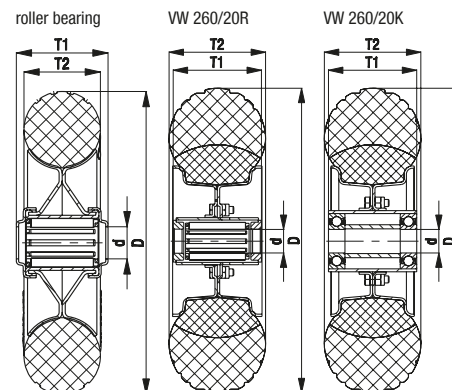

## L-VW, B-VW, BH-VW series

**Pressed steel castors, medium-duty version, with top plate, wheel with "Blickle Soft" soft rubber tyre**



50–200 kg

**Bracket:** L/B/BH series

- pressed steel, zinc-plated, blue-passivated, Cr6-free

**Swivel bracket:**

- double ball bearing in the swivel head
- strong central kingpin (from wheel Ø 150 mm)
- swivel head seal (exception: plate size 175x175 mm)
- minimum swivel head play and smooth rolling characteristic and increased service life due to the special dynamic Blickle riveting process

**Wheel:** VW series

- tyre: soft rubber "Blickle Soft", hardness 50 Shore A, colour black (wheel Ø 260 mm with additional hard rubber core)
- rim: pressed steel, strong rim structure with tubular steel hub, bolted or pressed, zinc-plated, blue-passivated, Cr6-free

**Additional details:**

- bracket series: page 91
- brakes: page 112–113
- wheel series: page 204
- bearing types: page 84–85

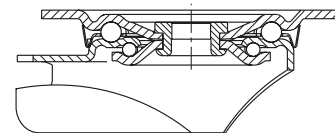

Swivel castors	Fixed castors	Swivel castors with "stop-fix" brake	Wheel Ø [mm]	Tyre width [mm]	Load capacity [kg]	Bearing type	Total height [mm]	Plate size [mm]	Bolt hole spacing [mm]	Bolt hole Ø [mm]	Offset swivel castor [mm]
L-VW 125R	B-VW 125R	L-VW 125R-FI	125	37.5	50	roller bearing	150	100 x 85	80 x 60	9	38
L-VW 162R	B-VW 162R	L-VW 162R-FI	160	40	70	roller bearing	195	140 x 110	105 x 75–80	11	60
L-VW 202R	B-VW 202R	L-VW 202R-FI	200	50	100	roller bearing	235	140 x 110	105 x 75–80	11	65
L-VW 252R-3	BH-VW 252R	*	250	60	160	roller bearing	295	140 x 110	105 x 75–80	11	77
L-VW 260R		*	260	85	200	roller bearing	308	175 x 175	140 x 140	15	78
	B-VW 260R		260	85	200	roller bearing	308	220 x 130	190 x 75	15	–
L-VW 260K		*	260	85	200	ball bearing	308	175 x 175	140 x 140	15	78
	B-VW 260K		260	85	200	ball bearing	308	220 x 130	190 x 75	15	–

\* "stop-top" brake version, see versions / options

### Versions / options



	with non-marking grey tyre	with thread guard, pressed steel, zinc-plated	with "stop-top" brake	directional lock (separate) 1 x 360°	directional lock (separate) 1 x 360°	with steel foot guard
Technical description page	52	116	112	115	115	116
<b>Product code suffix</b>	<b>-SG</b>	<b>-FA</b>	<b>-ST</b>	<b>RI-03.01</b>	<b>RI-05.03</b>	<b>-FS</b>
Available for	wheel Ø 125–200 mm, others upon request	wheel Ø 125–250 mm	all	wheel Ø 125 mm**	wheel Ø 160–200 mm**	up to wheel Ø 250 mm upon request

\*\* Only for swivel castors without brake or swivel castor with "stop-top" brake upon request

## RD series

Wheels with two-component solid rubber tyre,  
"Blickle Comfort"  
with pressed steel rim



100–650 kg

<b>Tread and tyre hardness</b>	65 Shore A
<b>Smooth operation / floor preservation</b>	very good
<b>Rolling resistance</b>	good
<b>Wear resistance</b>	satisfactory



- Tyre:**
- two-component solid rubber "Blickle Comfort", hardness 65 Shore A
  - hard rubber core and highly elastic tread
  - very good floor preservation, low-noise operation
  - additional operational comfort and load capacity compared to standard solid rubber
  - low rolling resistance
  - colour black

- Rim:**
- pressed steel
  - strong rim structure with tubular steel hub, bolted or pressed
  - zinc-plated, blue-passivated, Cr6-free

- Other features:**
- chemical resistance to many aggressive substances, except oils
  - operating temperature: -20 °C to +80 °C, reduced load capacity over +60 °C

- Additional details:**
- wheel series: page 62
  - tread: page 53
  - bearing types: page 84–85
  - chemical resistance: page 51

Wheels	Wheel Ø (D) [mm]	Tyre width (T2) [mm]	Load capacity [kg]	Bearing type	Axle bore Ø (d) [mm]	Hub length (T1) [mm]
RD 100/15R	100	30	100	roller bearing	15	45
RD 125/15R	125	37.5	120	roller bearing	15	45
RD 140/15R	140	37.5	175	roller bearing	15	45
RD 162/20R	160	40	225	roller bearing	20	60
RD 182/20R	180	50	300	roller bearing	20	60
RD 202/20R	200	50	350	roller bearing	20	60
RD 200/20K *	200	50	350	ball bearing	20	60
RD 252/25R	250	60	450	roller bearing	25	65
RD 250/25K *	250	60	450	ball bearing	25	65
RD 282/25R	280	70	650	roller bearing	25	75
RD 280/25K *	280	70	650	ball bearing	25	75

\* Bolted version

### Versions / options



with non-marking grey tyre, 56 shore A

Technical description page	52
Product code suffix	-VLI
Available for	wheel Ø 100–250 mm

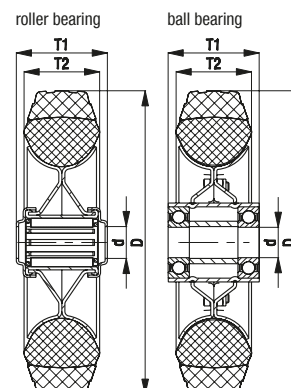



## L-RD, B-RD, BH-RD series

Pressed steel castors, medium-duty version, top plate, wheel with two-component "Blickle Comfort" solid rubber tyres



100–600 kg

**Bracket:** L/B/BH series

- pressed steel, zinc-plated, blue-passivated, Cr6-free

**Swivel bracket:**

- double ball bearing in the swivel head
- strong central kingpin (from wheel Ø 150 mm)
- swivel head seal (exception: plate size 175x175 mm)
- minimum swivel head play and smooth rolling characteristic and increased service life due to the special dynamic Blickle riveting process

**Wheel:** RD series

- tyre: two-component solid rubber "Blickle Comfort", hardness 65 Shore A, colour black
- rim: pressed steel, strong rim structure with tubular steel hub, bolted or pressed, zinc-plated, blue-passivated, Cr6-free

**Additional details:**

- bracket series: page 91
- brakes: page 112–113
- wheel series: page 206
- bearing types: page 84–85

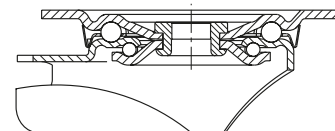

Swivel castors	Fixed castors	Swivel castors with "stop-fix" brake	Wheel Ø [mm]	Tyre width [mm]	Load capacity [kg]	Bearing type	Total height [mm]	Plate size [mm]	Bolt hole spacing [mm]	Bolt hole Ø [mm]	Offset swivel castor [mm]
L-RD 100R	B-RD 100R	L-RD 100R-FI	100	30	100	roller bearing	125	100 x 85	80 x 60	9	36
L-RD 125R	B-RD 125R	L-RD 125R-FI	125	37.5	120	roller bearing	150	100 x 85	80 x 60	9	38
L-RD 140R	B-RD 140R	L-RD 140R-FI	140	37.5	175	roller bearing	170	140 x 110	105 x 75–80	11	50
L-RD 162R	B-RD 162R	L-RD 162R-FI	160	40	225	roller bearing	195	140 x 110	105 x 75–80	11	60
L-RD 182R	B-RD 182R	L-RD 182R-FI	180	50	300	roller bearing	215	140 x 110	105 x 75–80	11	60
L-RD 202R	B-RD 202R	L-RD 202R-FI	200	50	350	roller bearing	235	140 x 110	105 x 75–80	11	65
L-RD 200K	B-RD 200K	L-RD 200K-FI	200	50	350	ball bearing	235	140 x 110	105 x 75–80	11	65
L-RD 252R-3	BH-RD 252R	*	250	60	450	roller bearing	295	140 x 110	105 x 75–80	11	77
L-RD 252R		*	250	60	450	roller bearing	295	175 x 175	140 x 140	15	70
	B-RD 252R		250	60	450	roller bearing	295	220 x 130	190 x 75	15	–
L-RD 250K		*	250	60	450	ball bearing	295	175 x 175	140 x 140	15	70
	B-RD 250K		250	60	450	ball bearing	295	220 x 130	190 x 75	15	–
L-RD 282R		*	280	70	600	roller bearing	318	175 x 175	140 x 140	15	78
	B-RD 282R		280	70	600	roller bearing	318	220 x 130	190 x 75	15	–
L-RD 280K		*	280	70	600	ball bearing	318	175 x 175	140 x 140	15	78
	B-RD 280K		280	70	600	ball bearing	318	220 x 130	190 x 75	15	–

\* "stop-top" brake version, see versions / options

### Versions / options



	with non-marking grey tyre, 56 shore A	with thread guard, pressed steel, zinc-plated	with "stop-top" brake	with "central-stop" central brake system	directional lock (separate) 1 x 360°	directional lock (separate) 1 x 360°	with steel foot guard
Technical description page	52	116	112	113	115	115	116
Product code suffix	-VLI	-FA	-ST	-CS11	RI-03.01	RI-05.03	-FS
Available for	wheel Ø 100–250 mm	wheel Ø 100–250 mm	all	wheel Ø 160+200 mm	wheel Ø 100–125 mm**	wheel Ø 160–200 mm**	all up to wheel Ø 200 mm, wheel Ø 250 mm upon request

\*\* Only for swivel castors without brake or swivel castor with "stop-top" and "central-stop" brake upon request

## LK-RD, BK-RD, BH-RD series

Pressed steel castors, heavy-duty design, top plate, wheel with two-component "Blickle Comfort" solid rubber tyre

100–350 kg

**Bracket:** LK/BK/BH series

- strong pressed steel, zinc-plated, blue-passivated, Cr6-free

**Swivel bracket:**

- double ball bearing in the swivel head
- strong central kingpin (from wheel Ø 125x50 mm)
- swivel head seal
- minimum swivel head play and smooth rolling characteristic and increased service life due to the special dynamic Blickle riveting process

**Wheel:** RD series

- tyre: two-component solid rubber "Blickle Comfort", hardness 65 Shore A, colour black
- rim: pressed steel, strong rim structure with tubular steel hub, bolted or pressed, zinc-plated, blue-passivated, Cr6-free

**Additional details:**

- bracket series: page 92
- brakes: page 112–113
- wheel series: page 206
- bearing types: page 84–85



3

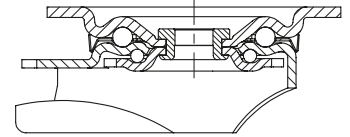

Swivel castors	Fixed castors	Swivel castors with "stop-fix" brake	Wheel Ø [mm]	Tyre width [mm]	Load capacity [kg]	Bearing type	Total height [mm]	Plate size [mm]	Bolt hole spacing [mm]	Bolt hole Ø [mm]	Offset swivel castor [mm]
LK-RD 100R-1	BK-RD 100R-1	LK-RD 100R-1-FI	100	30	100	roller bearing	130	100 x 85	80 x 60	9	45
LK-RD 100R-3	BK-RD 100R-3	LK-RD 100R-3-FI	100	30	100	roller bearing	130	140 x 110	105 x 75–80	11	45
LK-RD 125R-1	BK-RD 125R-1	LK-RD 125R-1-FI	125	37.5	120	roller bearing	155	100 x 85	80 x 60	9	48
LK-RD 125R-3	BK-RD 125R-3	LK-RD 125R-3-FI	125	37.5	120	roller bearing	155	140 x 110	105 x 75–80	11	48
LK-RD 162R	BH-RD 162R	LK-RD 162R-FI	160	40	225	roller bearing	202	140 x 110	105 x 75–80	11	60
LK-RD 202R	BH-RD 202R	LK-RD 202R-FI	200	50	350	roller bearing	245	140 x 110	105 x 75–80	11	62
LK-RD 200K	BH-RD 200K	LK-RD 200K-FI	200	50	350	ball bearing	245	140 x 110	105 x 75–80	11	62

### Versions / options



	with non-marking grey tyre, 56 shore A	with thread guard, pressed steel, zinc-plated	with "stop-top" brake	with "central-stop" central brake system	with directional lock (separate) 1x 360°	with steel foot guard
Technical description page	52	116	112	113	115	116
Product code suffix	-VLI	-FA	-ST	-CS11	see *	-FS
Available for	all	all	all	wheel Ø 100–125 mm	for wheel Ø and plate dimensions, see*	upon request

\* RI-05.01 for wheel Ø 100–125 mm with plate 100x85 mm, RI-03.03 for wheel Ø 100–125 mm with plate 140x110 mm, RI-05.03 for wheel Ø 160–200 mm (Only for swivel castors without brake or swivel castor with "stop-top" and "central-stop" brake upon request)

## POES, ALES series

Wheels with “Blickle SoftMotion” soft rubber tyres, with nylon or aluminium wheel centre

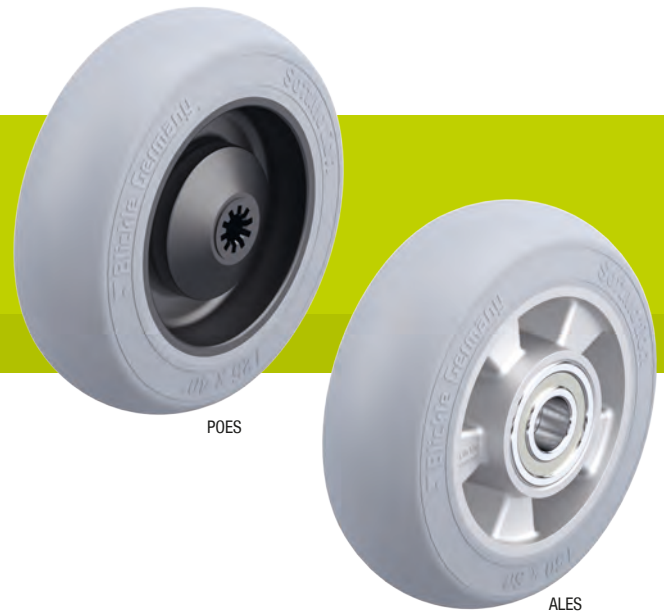

110–440 kg

<b>Tread and tyre hardness</b>	55 Shore A
<b>Smooth operation / floor preservation</b>	excellent
<b>Rolling resistance</b>	very good
<b>Wear resistance</b>	good



- Tyre:**
- high-quality elastic solid rubber “Blickle SoftMotion”, hardness 55 Shore A
  - maximum operational comfort
  - excellent floor preservation, particularly quiet operation
  - low rolling resistance
  - colour grey, non-marking
  - vulcanised onto the wheel centre

- Wheel centre:**
- POES series: high-quality nylon 6, impact resistant, colour black
  - series ALES: die-cast aluminium

- Other features:**
- KA version: with synthetic thread guard, small
  - KF version: with synthetic thread guard, large
  - high chemical resistance to many aggressive substances, except oils
  - operating temperature: -20 °C to +80 °C, reduced load capacity over +35 °C (POES) or +60 °C (ALES)

- Additional details:**
- wheel series: page 60
  - tread: page 53
  - bearing types: page 84–85
  - chemical resistance: page 51

Wheels	Wheel Ø (D) [mm]	Wheel width (T2) [mm]	Load capacity at 4 km/h [kg]	Load capacity at 10 km/h [kg]	Bearing type	Axle bore Ø (d) [mm]	Hub length (T1) [mm]
<b>POES</b>							
POES 80/8KF-SG	80	40	110	–	ball bearing (C)	8	46
POES 100/8KF-SG	100	40	150	–	ball bearing (C)	8	46
POES 125/8KA-SG	125	40	175	–	ball bearing (C)	8	46
POES 150/12KA-SG	150	50	280	–	ball bearing (CC)	12	62
POES 160/12KA-SG	160	50	300	–	ball bearing (CC)	12	62
POES 200/12KA-SG	200	50	350	–	ball bearing (CC)	12	62
<b>ALES</b>							
ALES 150/20K-SG	150	50	280	220	ball bearing	20	60
ALES 160/20K-SG	160	50	300	240	ball bearing	20	60
ALES 200/20K-SG	200	50	350	280	ball bearing	20	60
ALES 250/20K-SG	250	50	440	370	ball bearing	20	60

### Versions / options



	with stainless steel ball bearing and thread guard	thread guard with additional ball bearing seals
Technical description page	84–85	85
Product code suffix	-XKA / -XKF	-KAD / -KFD
Available for	POES series	upon request

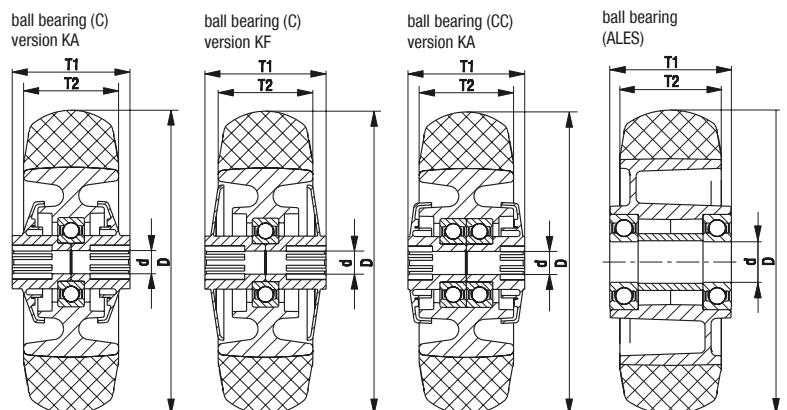

## LE-POES, B-POES, LK-POES, BK-POES series

Pressed steel castors with top plate,  
wheel with soft rubber tyre  
"Blickle SoftMotion"



110–300 kg

**Bracket:** LE/B, LK/BK series

- LE: pressed steel, zinc-plated, blue-passivated, Cr6-free
- LK: strong pressed steel, zinc-plated, blue-passivated, Cr6-free

**Swivel bracket:**

- double ball bearing in the swivel head
- swivel head seal
- minimum swivel head play and smooth rolling characteristic and increased service life due to the special dynamic Blickle riveting process

**Wheel:** POES series

- tyre: high-quality elastic solid rubber "Blickle SoftMotion", hardness 55 Shore A, colour grey, non-marking
- wheel centre: high-quality nylon 6, impact resistant, colour black

**Additional details:**

- bracket series: page 90, 92
- brakes: page 112–113
- wheel series: page 209
- bearing types: page 84–85



3

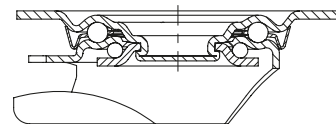

Swivel castors	Fixed castors	Swivel castors with "stop-fix" brake	Wheel Ø [mm]	Wheel width [mm]	Load capacity [kg]	Bearing type	Total height [mm]	Plate size [mm]	Bolt hole spacing [mm]	Bolt hole Ø [mm]	Offset swivel castor [mm]
LK-POES 80KF-SG	BK-POES 80KF-SG	LK-POES 80KF-FI-SG	80	40	110	ball bearing (C)	110	100 x 85	80 x 60	9	40
LE-POES 100KF-SG	B-POES 100KF-SG	LE-POES 100KF-FI-SG	100	40	150	ball bearing (C)	125	100 x 85	80 x 60	9	36
LE-POES 125KA-SG	B-POES 125KA-SG	LE-POES 125KA-FI-SG	125	40	150	ball bearing (C)	150	100 x 85	80 x 60	9	38
LE-POES 150KA-SG	B-POES 150KA-SG	LE-POES 150KA-FI-SG	150	50	280	ball bearing (CC)	190	140 x 110	105 x 75–80	11	54
LE-POES 160KA-SG	B-POES 160KA-SG	LE-POES 160KA-FI-SG	160	50	300	ball bearing (CC)	195	140 x 110	105 x 75–80	11	54
LE-POES 200KA-SG	B-POES 200KA-SG	LE-POES 200KA-FI-SG	200	50	300	ball bearing (CC)	235	140 x 110	105 x 75–80	11	54

### Versions / options



	with "stop-top" brake	with "central-stop" central brake system	with steel foot guard	with aluminium wheel centre
Technical description page	112	113	116	
Product code suffix	-ST	-CS11	-FS	LE-ALES series
Available for	wheel Ø 150–200 mm	wheel Ø 160–200 mm	upon request	upon request

## LER-POES, LKR-POES series

**Pressed steel castors with bolt hole,  
wheel with soft rubber tyres  
"Blickle SoftMotion"**



110–150 kg

**Bracket:** LER/LKR series

- LER: pressed steel, zinc-plated, blue-passivated, Cr6-free
- LKR: strong pressed steel, zinc-plated, blue-passivated, Cr6-free
- double ball bearing in the swivel head
- strong central kingpin
- minimum swivel head play and smooth rolling characteristic and increased service life due to the special dynamic Blickle riveting process

**Wheel:** POES series

- tyre: high-quality elastic solid rubber "Blickle SoftMotion", hardness 55 Shore A, colour grey, non-marking
- wheel centre: high-quality nylon 6, impact resistant, colour black

**Additional details:**

- bracket series: page 91, 92
- brakes: page 112–113
- wheel series: page 209
- bearing types: page 84–85



3

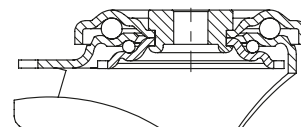

Swivel castors	Swivel castors with "stop-fix" brake	Wheel Ø [mm]	Wheel width [mm]	Load capacity [kg]	Bearing type	Total height [mm]	Plate Ø [mm]	Bolt hole Ø [mm]	Offset swivel castor [mm]
LKR-POES 80KF-SG	LKR-POES 80KF-FI-SG	80	40	110	ball bearing (C)	110	88	13	40
LER-POES 100KF-SG	LER-POES 100KF-FI-SG	100	40	150	ball bearing (C)	125	70	13	36
LER-POES 125KA-SG	LER-POES 125KA-FI-SG	125	40	150	ball bearing (C)	150	70	13	38

### Versions / options

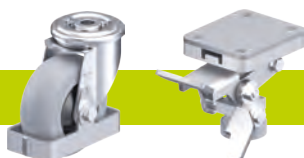

	with steel foot guard	truck lock
Technical description page	116	114
Product code suffix	-FS	FF 100-1 / FF 125-1
Available for	upon request	wheel Ø 100+125 mm

## POEV series (wheel Ø 60–125 mm)

### Heavy-duty wheels with elastic solid rubber tyre “Blickle EasyRoll”, with nylon wheel centre

120–250 kg

**Tread and tyre hardness**  
 65 Shore A

**Smooth operation / floor preservation**  
 very good

**Rolling resistance**  
 very good

**Wear resistance**  
 good

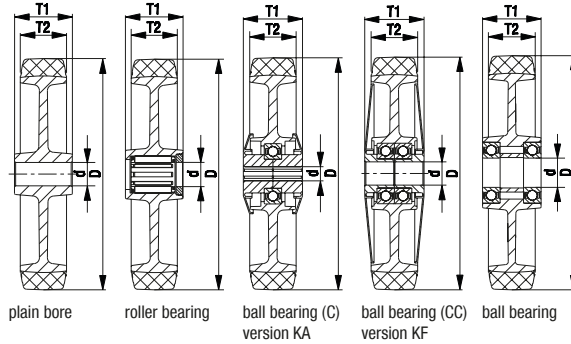

#### Tyre:

- high-quality elastic solid rubber “Blickle EasyRoll” in smooth rolling quality, hardness 65 Shore A
- very good operational comfort
- very good floor preservation, low-noise operation
- low rolling resistance
- colour black
- vulcanised onto the wheel centre

#### Wheel centre:

- high-quality nylon 6, impact resistant
- colour black

#### Other features:

- KA version: with synthetic thread guard, small
- KF version: with synthetic thread guard, large
- high chemical resistance to many aggressive substances, except oils
- operating temperature: -20 °C to +80 °C, temporarily up to +100 °C, reduced load capacity over +35 °C

#### Additional details:

- wheel series: page 63
- tread: page 53
- bearing types: page 84–85
- chemical resistance: page 51

Wheels	Wheel Ø (D) [mm]	Wheel width (T2) [mm]	Load capacity [kg]	Bearing type	Axle bore Ø (d) [mm]	Hub length (T1) [mm]
POEV 60/8KF	60	34	120	ball bearing (CC)	8	36
POEV 80/12G	80	32	140	plain bore	12	35
POEV 80/12R	80	32	140	roller bearing	12	35
POEV 80/8KF	80	32	140	ball bearing (C)	8	36
POEV 82/8KF	80	40	170	ball bearing (C)	8	46
POEV 82/10KF	80	40	170	ball bearing (C)	10	46
POEV 100/12G	100	32	200	plain bore	12	45
POEV 100/12R	100	32	200	roller bearing	12	45
POEV 100/15R	100	32	200	roller bearing	15	45
POEV 100/8KA	100	32	200	ball bearing (C)	8	46
POEV 100/10KA	100	32	200	ball bearing (C)	10	46
POEV 100/15K	100	32	200	ball bearing	15	45
POEV 125/12G	125	37	250	plain bore	12	45
POEV 125/12R	125	37	250	roller bearing	12	45
POEV 125/15R	125	37	250	roller bearing	15	45
POEV 125/8KA	125	37	250	ball bearing (C)	8	46
POEV 125/10KA	125	37	250	ball bearing (C)	10	46
POEV 125/15K	125	37	250	ball bearing	15	45
POEV 125/20K	125	37	250	ball bearing	20	45

For other wheel Ø, see next page

### Versions / options

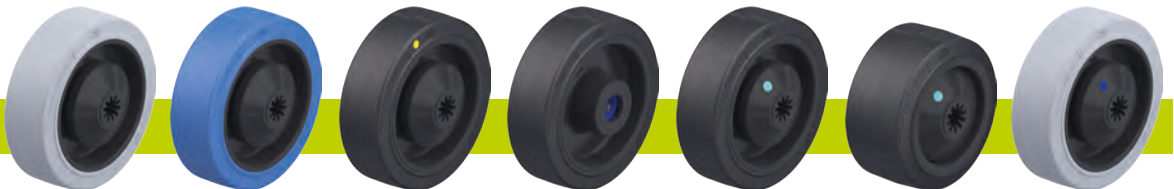

	with non-marking grey tyre	with non-marking blue tyre	electrically conductive version, black tyre	with stainless steel roller bearing in the wheel hub	small thread guard with additional ball bearing seal	large thread guard with additional ball bearing seals	with stainless steel ball bearing and thread guard
Technical description page	52	53	50	84	85	85	84–85
Product code suffix	-SG	-SB	-EL	-XR	-KAD	-KFD	-XKA / -XKF
Available for	all	wheel Ø 80x32, 100, 125 mm	ball bearing versions upon request	all	all KA versions	all KF versions	all KA- and KF- versions of version -SG*

\* With exception of wheel Ø 60 mm

## POEV series (wheel Ø 160–300 mm)

### Heavy-duty wheels with elastic solid rubber tyre “Blickle EasyRoll”, with nylon wheel centre

320–650 kg

**Tread and tyre hardness**

65 Shore A

**Smooth operation / floor preservation**

very good

**Rolling resistance**

very good

**Wear resistance**

good

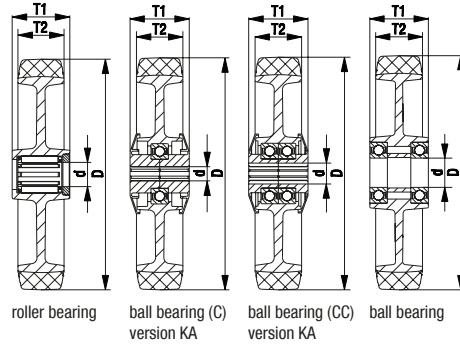

**Tyre:**

- high-quality elastic solid rubber “Blickle EasyRoll” in smooth rolling quality, hardness 65 Shore A
- very good operational comfort
- very good floor preservation, low-noise operation
- low rolling resistance
- colour black
- vulcanised onto the wheel centre

**Wheel centre:**

- high-quality nylon 6, impact resistant
- colour black

**Other features:**

- KA version: with synthetic thread guard, small
- high chemical resistance to many aggressive substances, except oils
- operating temperature: -20 °C to +80 °C, temporarily up to +100 °C, reduced load capacity over +35 °C

**Additional details:**

- wheel series: page 63
- tread: page 53
- bearing types: page 84–85
- chemical resistance: page 51

Wheels	Wheel Ø (D) [mm]	Wheel width (T2) [mm]	Load capacity [kg]	Bearing type	Axle bore Ø (d) [mm]	Hub length (T1) [mm]
POEV 161/20R	160	40	320	roller bearing	20	60
POEV 161/12KA	160	40	320	ball bearing (C)	12	62
POEV 161/20KA	160	40	320	ball bearing (C)	20	60
POEV 160/20R	160	50	400	roller bearing	20	60
POEV 160/12KA	160	50	400	ball bearing (CC)	12	62
POEV 160/20K	160	50	400	ball bearing	20	60
POEV 201/20R	200	40	400	roller bearing	20	60
POEV 201/12KA	200	40	400	ball bearing (C)	12	62
POEV 201/20KA	200	40	400	ball bearing (C)	20	60
POEV 200/20R	200	50	500	roller bearing	20	60
POEV 200/12KA	200	50	500	ball bearing (CC)	12	62
POEV 200/20K	200	50	500	ball bearing	20	60
POEV 200/25K	200	50	500	ball bearing	25	60
POEV 250/25R	250	50	600	roller bearing	25	60
POEV 250/20K	250	50	600	ball bearing	20	60
POEV 250/25K	250	50	600	ball bearing	25	60
POEV 300/30K	300	60	650	ball bearing	30	70

### Versions / options



	with non-marking grey tyre	with non-marking blue tyre	electrically conductive version, black tyre	with stainless steel roller bearing in the wheel hub	small thread guard with additional ball bearing seal	with stainless steel ball bearing and small thread guard
Technical description page	52	53	50	84	85	85
<b>Product code suffix</b>	<b>-SG</b>	<b>-SB</b>	<b>-EL</b>	<b>-XR</b>	<b>-KAD</b>	<b>-XKA</b>
Available for	wheel Ø 160–200, 250 mm (ball bearing versions)	wheel Ø 160x50, 200x50, 250 mm (ball bearing versions)	ball bearing versions upon request	all	all KA versions	all KA versions of version -SG, POEV 160/12KA and POEV 200/12KA

## LE-POEV, B-POEV series

Pressed steel castors with top plate,  
wheel with "Blickle EasyRoll" elastic solid rubber tyre



120–300 kg

**Bracket:** LE/B series

- pressed steel, zinc-plated, blue-passivated, Cr6-free

Swivel bracket:

- double ball bearing in the swivel head
- swivel head seal
- minimum swivel head play and smooth rolling characteristic and increased service life due to the special dynamic Blickle riveting process

**Wheel:** POEV series

- tyre: high-quality elastic solid rubber "Blickle EasyRoll" in smooth rolling quality, hardness 65 Shore A, colour black
- wheel centre: high-quality nylon 6, impact resistant, colour black

**Additional details:**

- bracket series: page 90
- brakes: page 112–113
- wheel series: page 212–213
- bearing types: page 84–85



3

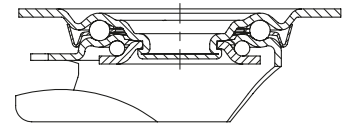

Swivel castors	Fixed castors	Swivel castors with "stop-fix" brake	Wheel Ø [mm]	Wheel width [mm]	Load capacity [kg]	Bearing type	Total height [mm]	Plate size [mm]	Bolt hole spacing [mm]	Bolt hole Ø [mm]	Offset swivel castor [mm]
LE-POEV 60KF	B-POEV 60KF	LE-POEV 60KF-RA *	60	34	120	ball bearing (CC)	80	100 x 85	80 x 60	9	35
LE-POEV 80G	B-POEV 80G	LE-POEV 80G-FI	80	32	140	plain bore	102	100 x 85	80 x 60	9	38
LE-POEV 80R	B-POEV 80R	LE-POEV 80R-FI	80	32	140	roller bearing	102	100 x 85	80 x 60	9	38
LE-POEV 80KF	B-POEV 80KF	LE-POEV 80KF-FI	80	32	140	ball bearing (C)	102	100 x 85	80 x 60	9	38
LE-POEV 100G	B-POEV 100G	LE-POEV 100G-FI	100	32	150	plain bore	125	100 x 85	80 x 60	9	36
LE-POEV 100R	B-POEV 100R	LE-POEV 100R-FI	100	32	150	roller bearing	125	100 x 85	80 x 60	9	36
LE-POEV 100KA	B-POEV 100KA	LE-POEV 100KA-FI	100	32	150	ball bearing (C)	125	100 x 85	80 x 60	9	36
LE-POEV 125G	B-POEV 125G	LE-POEV 125G-FI	125	37	150	plain bore	150	100 x 85	80 x 60	9	38
LE-POEV 125R	B-POEV 125R	LE-POEV 125R-FI	125	37	150	roller bearing	150	100 x 85	80 x 60	9	38
LE-POEV 125KA	B-POEV 125KA	LE-POEV 125KA-FI	125	37	150	ball bearing (C)	150	100 x 85	80 x 60	9	38
LE-POEV 161R	B-POEV 161R	LE-POEV 161R-FI	160	40	300	roller bearing	195	140 x 110	105 x 75–80	11	54
LE-POEV 161KA	B-POEV 161KA	LE-POEV 161KA-FI	160	40	300	ball bearing (C)	195	140 x 110	105 x 75–80	11	54
LE-POEV 160R	B-POEV 160R	LE-POEV 160R-FI	160	50	300	roller bearing	195	140 x 110	105 x 75–80	11	54
LE-POEV 160KA	B-POEV 160KA	LE-POEV 160KA-FI	160	50	300	ball bearing (CC)	195	140 x 110	105 x 75–80	11	54
LE-POEV 201R	B-POEV 201R	LE-POEV 201R-FI	200	40	300	roller bearing	235	140 x 110	105 x 75–80	11	54
LE-POEV 201KA	B-POEV 201KA	LE-POEV 201KA-FI	200	40	300	ball bearing (C)	235	140 x 110	105 x 75–80	11	54
LE-POEV 200R	B-POEV 200R	LE-POEV 200R-FI	200	50	300	roller bearing	235	140 x 110	105 x 75–80	11	54
LE-POEV 200KA	B-POEV 200KA	LE-POEV 200KA-FI	200	50	300	ball bearing (CC)	235	140 x 110	105 x 75–80	11	54

\* "Radstop" brake version

For stainless steel versions, see page 403

### Versions / options\*\*



	"Radstop" wheel brake	with non-marking grey tyre	with non-marking blue tyre	electrically conductive version, black tyre	with thread guard, pressed steel, zinc-plated	with "stop-top" brake	with "central-stop" central brake system
Technical description page		52	53	50	116	112	113
Product code suffix		-SG	-SB	-EL	-FA	-ST	-CS11
Available for	LE-POEV 60KF	all	wheel Ø 80–125, 160x50, 200x50 mm	ball bearing versions upon request	all, with exception of versions with KF and wheel width 40 mm	wheel Ø 160–200 mm	wheel Ø 160–200 mm

\*\* Other versions / options: 1. directional lock (separate) 1 x 360°: RI-03.01 for wheel Ø 100–125 mm, RI-03.03 for wheel Ø 160–200 mm (only for swivel castors without brake or swivel castor with "stop-top" and "central-stop" brake upon request) 2. stainless steel wheel bearing or ball bearing seal: see versions / options page 212–213 3. with steel foot guard (-FS), upon request



## LER-POEV series

Pressed steel castors with bolt hole,  
wheel with "Blickle EasyRoll" elastic solid rubber tyre



120–300 kg

**Bracket:** LER series

- pressed steel, zinc-plated, blue-passivated, Cr6-free
- double ball bearing in the swivel head
- strong central kingpin
- minimum swivel head play and smooth rolling characteristic and increased service life due to the special dynamic Blickle riveting process

**Wheel:** POEV series

- tyre: high-quality elastic solid rubber "Blickle EasyRoll" in smooth rolling quality, hardness 65 Shore A, colour black
- wheel centre: high-quality nylon 6, impact resistant, colour black

**Additional details:**

- bracket series: page 91
- brakes: page 112–113
- wheel series: page 212–213
- bearing types: page 84–85

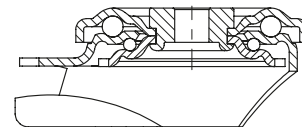

Swivel castors	Swivel castors with "stop-fix" brake	Wheel Ø [mm]	Wheel width [mm]	Load capacity [kg]	Bearing type	Total height [mm]	Plate Ø [mm]	Bolt hole Ø [mm]	Offset swivel castor [mm]
LER-POEV 60KF	LER-POEV 60KF-RA *	60	34	120	ball bearing (CC)	80	70	13	35
LER-POEV 80G	LER-POEV 80G-FI	80	32	140	plain bore	102	70	13	38
LER-POEV 80R	LER-POEV 80R-FI	80	32	140	roller bearing	102	70	13	38
LER-POEV 80KF	LER-POEV 80KF-FI	80	32	140	ball bearing (C)	102	70	13	38
LER-POEV 100G	LER-POEV 100G-FI	100	32	150	plain bore	125	70	13	36
LER-POEV 100R	LER-POEV 100R-FI	100	32	150	roller bearing	125	70	13	36
LER-POEV 100KA	LER-POEV 100KA-FI	100	32	150	ball bearing (C)	125	70	13	36
LER-POEV 125G	LER-POEV 125G-FI	125	37	150	plain bore	150	70	13	38
LER-POEV 125R	LER-POEV 125R-FI	125	37	150	roller bearing	150	70	13	38
LER-POEV 125KA	LER-POEV 125KA-FI	125	37	150	ball bearing (C)	150	70	13	38
LER-POEV 161R	LER-POEV 161R-FI	160	40	300	roller bearing	195	88	13	54
LER-POEV 161KA	LER-POEV 161KA-FI	160	40	300	ball bearing (C)	195	88	13	54
LER-POEV 160R	LER-POEV 160R-FI	160	50	300	roller bearing	195	88	13	54
LER-POEV 160KA	LER-POEV 160KA-FI	160	50	300	ball bearing (CC)	195	88	13	54
LER-POEV 201R	LER-POEV 201R-FI	200	40	300	roller bearing	235	88	13	54
LER-POEV 201KA	LER-POEV 201KA-FI	200	40	300	ball bearing (C)	235	88	13	54
LER-POEV 200R	LER-POEV 200R-FI	200	50	300	roller bearing	235	88	13	54
LER-POEV 200KA	LER-POEV 200KA-FI	200	50	300	ball bearing (CC)	235	88	13	54

\* "Radstop" brake version

For stainless steel versions, see page 404

### Versions / options



	with non-marking grey tyre	with non-marking blue tyre	electrically conductive version, black tyre	with thread guard, pressed steel, zinc-plated	with stainless steel roller bearing / ball bearing	with steel foot guard	truck lock
Technical description page	52	53	50	116	84 / 85	116	114
Product code suffix	-SG	-SB	-EL	-FA	-XR / -XKA / XKF	-FS	FF 100-1 / FF 125-1
Available for	all	wheel Ø 80–125, 160x50, 200x50 mm	ball bearing versions upon request	all, with exception of versions with KF and wheel width 40 mm	see versions / options page 212–213	upon request	wheel Ø 100+125 mm

## L-POEV, B-POEV, BH-POEV series

Pressed steel castors, medium-duty version, with top plate, wheel with "Blickle EasyRoll" elastic solid rubber tyres

140–500 kg

**Bracket:** L/B/BH series

- pressed steel, zinc-plated, blue-passivated, Cr6-free

**Swivel bracket:**

- double ball bearing in the swivel head
- strong central kingpin (from wheel Ø 150 mm)
- swivel head seal
- minimum swivel head play and smooth rolling characteristic and increased service life due to the special dynamic Blickle riveting process

**Wheel:** POEV series

- tyre: high-quality elastic solid rubber "Blickle EasyRoll" in smooth rolling quality, hardness 65 Shore A, colour black
- wheel centre: high-quality nylon 6, impact resistant, colour black

**Additional details:**

- bracket series: page 91
- brakes: page 112–113
- wheel series: page 212–213
- bearing types: page 84–85



3

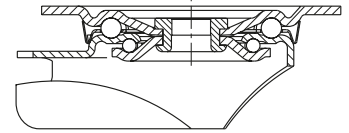

Swivel castors	Fixed castors	Swivel castors with "stop-fix" brake	Wheel Ø [mm]	Wheel width [mm]	Load capacity [kg]	Bearing type	Total height [mm]	Plate size [mm]	Bolt hole spacing [mm]	Bolt hole Ø [mm]	Offset swivel castor [mm]
L-POEV 80G	B-POEV 80G	L-POEV 80G-FI	80	32	140	plain bore	102	100 x 85	80 x 60	9	38
L-POEV 80R	B-POEV 80R	L-POEV 80R-FI	80	32	140	roller bearing	102	100 x 85	80 x 60	9	38
L-POEV 80KF	B-POEV 80KF	L-POEV 80KF-FI	80	32	140	ball bearing (C)	102	100 x 85	80 x 60	9	38
L-POEV 100G	B-POEV 100G	L-POEV 100G-FI	100	32	200	plain bore	125	100 x 85	80 x 60	9	36
L-POEV 100R	B-POEV 100R	L-POEV 100R-FI	100	32	200	roller bearing	125	100 x 85	80 x 60	9	36
L-POEV 100KA	B-POEV 100KA	L-POEV 100KA-FI	100	32	200	ball bearing (C)	125	100 x 85	80 x 60	9	36
L-POEV 125G	B-POEV 125G	L-POEV 125G-FI	125	37	250	plain bore	150	100 x 85	80 x 60	9	38
L-POEV 125R	B-POEV 125R	L-POEV 125R-FI	125	37	250	roller bearing	150	100 x 85	80 x 60	9	38
L-POEV 125KA	B-POEV 125KA	L-POEV 125KA-FI	125	37	250	ball bearing (C)	150	100 x 85	80 x 60	9	38
L-POEV 161R	B-POEV 161R	L-POEV 161R-FI	160	40	320	roller bearing	195	140 x 110	105 x 75–80	11	60
L-POEV 161KA	B-POEV 161KA	L-POEV 161KA-FI	160	40	320	ball bearing (C)	195	140 x 110	105 x 75–80	11	60
L-POEV 160R	B-POEV 160R	L-POEV 160R-FI	160	50	400	roller bearing	195	140 x 110	105 x 75–80	11	60
L-POEV 160KA	B-POEV 160KA	L-POEV 160KA-FI	160	50	400	ball bearing (CC)	195	140 x 110	105 x 75–80	11	60
L-POEV 201R	B-POEV 201R	L-POEV 201R-FI	200	40	400	roller bearing	235	140 x 110	105 x 75–80	11	65
L-POEV 201KA	B-POEV 201KA	L-POEV 201KA-FI	200	40	400	ball bearing (C)	235	140 x 110	105 x 75–80	11	65
L-POEV 200R	B-POEV 200R	L-POEV 200R-FI	200	50	400	roller bearing	235	140 x 110	105 x 75–80	11	65
L-POEV 200KA	B-POEV 200KA	L-POEV 200KA-FI	200	50	400	ball bearing (CC)	235	140 x 110	105 x 75–80	11	65
L-POEV 250R-3	BH-POEV 250R	*	250	50	500	roller bearing	295	140 x 110	105 x 75–80	11	77
L-POEV 250K-3	BH-POEV 250K	*	250	50	500	ball bearing	295	140 x 110	105 x 75–80	11	77

\* "stop-top" brake version, see versions / options

For stainless steel versions, see page 405

### Versions / options\*\*



	with non-marking grey tyre	with non-marking blue tyre	electrically conductive version, black tyre	with thread guard, pressed steel, zinc-plated	with "stop-top" brake	with "central-stop" central brake system	with steel foot guard
Technical description page	52	53	50	116	112	113	116
Product code suffix	-SG	-SB	-EL	-FA	-ST	-CS11	-FS
Available for	all wheel Ø 80–200 mm Ø 250 ball bearing only	wheel Ø 80–125, 160x50, 200x50 mm	ball bearing versions upon request	all, with exception of versions with KF and wheel width 40 mm	wheel Ø 80–250 mm	wheel Ø 160+200 mm	wheel Ø 100–250 mm upon request

\*\* Other versions / options: 1. directional lock (separate) 1 x 360°: RI-03.01 for wheel Ø 100–125 mm, RI-05.03 for wheel Ø 160–200 mm (only for swivel castors without brake or swivel castor with "stop-top" and "central-stop" brake upon request) 2. stainless steel wheel bearing or ball bearing seal: see versions / options page 212–213

## LK-POEV, BK-POEV, BH-POEV series

Pressed steel castors, heavy-duty design, with top plate, wheel with "Blickle EasyRoll" elastic solid rubber tyre

170–500 kg

**Bracket:** LK/BK/BH series

- strong pressed steel, zinc-plated, blue-passivated, Cr6-free

**Swivel bracket:**

- double ball bearing in the swivel head
- strong central kingpin (from wheel Ø 125x50 mm)
- swivel head seal
- minimum swivel head play and smooth rolling characteristic and increased service life due to the special dynamic Blickle riveting process

**Wheel:** POEV series

- tyre: high-quality elastic solid rubber "Blickle EasyRoll" in smooth rolling quality, hardness 65 Shore A, colour black
- wheel centre: high-quality nylon 6, impact resistant, colour black

**Additional details:**

- bracket series: page 92
- brakes: page 112–113
- wheel series: page 212–213
- bearing types: page 84–85

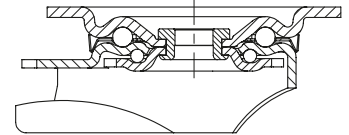

Swivel castors	Fixed castors	Swivel castors with "stop-fix" brake	Wheel Ø [mm]	Wheel width [mm]	Load capacity [kg]	Bearing type	Total height [mm]	Plate size [mm]	Bolt hole spacing [mm]	Bolt hole Ø [mm]	Offset swivel castor [mm]
LK-POEV 82KF	BK-POEV 82KF	LK-POEV 82KF-FI	80	40	170	ball bearing (C)	110	100 x 85	80 x 60	9	40
LK-POEV 100R-1	BK-POEV 100R-1	LK-POEV 100R-1-FI	100	32	200	roller bearing	130	100 x 85	80 x 60	9	45
LK-POEV 100KA-1	BK-POEV 100KA-1	LK-POEV 100KA-1-FI	100	32	200	ball bearing (C)	130	100 x 85	80 x 60	9	45
LK-POEV 100R-3	BK-POEV 100R-3	LK-POEV 100R-3-FI	100	32	200	roller bearing	130	140 x 110	105 x 75–80	11	45
LK-POEV 100KA-3	BK-POEV 100KA-3	LK-POEV 100KA-3-FI	100	32	200	ball bearing (C)	130	140 x 110	105 x 75–80	11	45
LK-POEV 125R-1	BK-POEV 125R-1	LK-POEV 125R-1-FI	125	37	250	roller bearing	155	100 x 85	80 x 60	9	48
LK-POEV 125KA-1	BK-POEV 125KA-1	LK-POEV 125KA-1-FI	125	37	250	ball bearing (C)	155	100 x 85	80 x 60	9	48
LK-POEV 125R-3	BK-POEV 125R-3	LK-POEV 125R-3-FI	125	37	250	roller bearing	155	140 x 110	105 x 75–80	11	48
LK-POEV 125KA-3	BK-POEV 125KA-3	LK-POEV 125KA-3-FI	125	37	250	ball bearing (C)	155	140 x 110	105 x 75–80	11	48
LK-POEV 160R	BH-POEV 160R	LK-POEV 160R-FI	160	50	400	roller bearing	202	140 x 110	105 x 75–80	11	60
LK-POEV 160KA	BH-POEV 160KA	LK-POEV 160KA-FI	160	50	400	ball bearing (CC)	202	140 x 110	105 x 75–80	11	60
LK-POEV 200R	BH-POEV 200R	LK-POEV 200R-FI	200	50	500	roller bearing	245	140 x 110	105 x 75–80	11	62
LK-POEV 200KA	BH-POEV 200KA	LK-POEV 200KA-FI	200	50	500	ball bearing (CC)	245	140 x 110	105 x 75–80	11	62

For stainless steel versions, see page 406

Versions / options \*



	with non-marking grey tyre	with non-marking blue tyre	electrically conductive version, black tyre	with "stop-top" brake	with "central-stop" central brake system	with "ideal-stop" brake total height +17 mm	with steel foot guard
Technical description page	52	53	50	112	113	112	116
Product code suffix	-SG	-SB	-EL	-ST	-CS11	-IS	-FS
Available for	all	wheel Ø 100–200 mm	ball bearing versions upon request	all	wheel Ø 100–125 mm	wheel Ø 100–200 mm with plate 140x110 mm**	wheel Ø 100–200 mm upon request

\* Other versions / options: 1. pressed steel thread guard, zinc-plated (-FA), available for wheel Ø 100–200 mm; 2. stainless steel wheel bearing or ball bearing seal: see versions / options page 212–213  
 3. directional lock (separate) 1 x 360°: RI-05.01 for wheel Ø 80–125 mm with 100x85 mm plate, RI-03.03 for wheel Ø 100–125 mm with 140x110 mm plate, RI-05.03 for wheel Ø 160–200 mm (only for swivel castors without brake or swivel castor with "stop-top" and "central-stop" brake upon request)

\*\* Synthetic adapter plate to balance out total height for swivel and fixed castors without "ideal-stop" brake: product code AP3-17

## LKR-POEV series

**Pressed steel castors, heavy-duty design, with bolt hole, wheel with "Blickle EasyRoll" elastic solid rubber tyre**



170–250 kg

**Bracket:** LKR series

- strong pressed steel, zinc-plated, blue-passivated, Cr6-free
- double ball bearing in the swivel head
- strong central kingpin
- minimum swivel head play and smooth rolling characteristic and increased service life due to the special dynamic Blickle riveting process

**Wheel:** POEV series

- tyre: high-quality elastic solid rubber "Blickle EasyRoll" in smooth rolling quality, hardness 65 Shore A, colour black
- wheel centre: high-quality nylon 6, impact resistant, colour black

**Additional details:**

- bracket series: page 92
- brakes: page 112–113
- wheel series: page 212–213
- bearing types: page 84–85

3

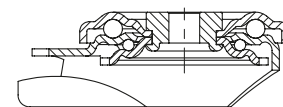

Swivel castors	Swivel castors with "stop-fix" brake	Wheel Ø [mm]	Wheel width [mm]	Load capacity [kg]	Bearing type	Total height [mm]	Plate Ø [mm]	Bolt hole Ø [mm]	Offset swivel castor [mm]
LKR-POEV 82KF	LKR-POEV 82KF-FI	80	40	170	ball bearing (C)	110	88	13	40
LKR-POEV 100R	LKR-POEV 100R-FI	100	32	200	roller bearing	130	88	13	45
LKR-POEV 100KA	LKR-POEV 100KA-FI	100	32	200	ball bearing (C)	130	88	13	45
LKR-POEV 125R	LKR-POEV 125R-FI	125	37	250	roller bearing	155	88	13	48
LKR-POEV 125KA	LKR-POEV 125KA-FI	125	37	250	ball bearing (C)	155	88	13	48

### Versions / options



	with non-marking grey tyre	with non-marking blue tyre	electrically conductive version, black tyre	with thread guard, pressed steel, zinc-plated	with stainless steel roller bearing / ball bearing	small thread guard with additional ball bearing seal	truck lock
Technical description page	52	53	50	116	84 / 85	85	114
<b>Product code suffix</b>	<b>-SG</b>	<b>-SB</b>	<b>-EL</b>	<b>-FA</b>	<b>-XR / -XKA / XKF</b>	<b>-KAD</b>	<b>FF 100-1 / FF 125-1</b>
Available for	all	wheel Ø 100–125 mm	ball bearing versions upon request	all with exception of wheel Ø 80 mm	see versions / options page 212	ball bearing versions	wheel Ø 100+125 mm

## LH-POEV, BH-POEV series

Pressed steel castors, heavy-duty design, with top plate, wheel with "Blickle EasyRoll" elastic solid rubber tyre

170–600 kg

**Bracket:** LH/BH series

- strong pressed steel, zinc-plated, blue-passivated, Cr6-free
- heavy fork and top plate

**Swivel bracket:**

- double ball bearing in the swivel head
- bolted and secured central kingpin, extremely strong
- particularly resistant to shocks and impact due to **four specially-shaped, hardened bearing seats**

**Wheel:** POEV series

- tyre: high-quality elastic solid rubber "Blickle EasyRoll" in smooth rolling quality, hardness 65 Shore A, colour black
- wheel centre: high-quality nylon 6, impact resistant, colour black

**Additional details:**

- bracket series: page 92
- brakes: page 112–113
- wheel series: page 212–213
- bearing types: page 84–85

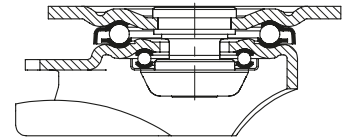

Swivel castors	Fixed castors	Swivel castors with "stop-fix" brake	Wheel Ø [mm]	Wheel width [mm]	Load capacity [kg]	Bearing type	Total height [mm]	Plate size [mm]	Bolt hole spacing [mm]	Bolt hole Ø [mm]	Offset swivel castor [mm]
LH-POEV 82KF	BH-POEV 82KF	LH-POEV 82KF-FI	80	40	170	ball bearing (C)	120	100 x 85	80 x 60	9	45
LH-POEV 100R-1	BH-POEV 100R-1	LH-POEV 100R-1-FI	100	32	200	roller bearing	140	100 x 85	80 x 60	9	45
LH-POEV 100K-1	BH-POEV 100K-1	LH-POEV 100K-1-FI	100	32	200	ball bearing	140	100 x 85	80 x 60	9	45
LH-POEV 100R-3	BH-POEV 100R-3	LH-POEV 100R-3-FI	100	32	200	roller bearing	140	140 x 110	105 x 75–80	11	45
LH-POEV 100K-3	BH-POEV 100K-3	LH-POEV 100K-3-FI	100	32	200	ball bearing	140	140 x 110	105 x 75–80	11	45
LH-POEV 125R-1	BH-POEV 125R-1	LH-POEV 125R-1-FI	125	37	250	roller bearing	165	100 x 85	80 x 60	9	45
LH-POEV 125K-1	BH-POEV 125K-1	LH-POEV 125K-1-FI	125	37	250	ball bearing	165	100 x 85	80 x 60	9	45
LH-POEV 125R-3	BH-POEV 125R-3	LH-POEV 125R-3-FI	125	37	250	roller bearing	165	140 x 110	105 x 75–80	11	45
LH-POEV 125K-3	BH-POEV 125K-3	LH-POEV 125K-3-FI	125	37	250	ball bearing	165	140 x 110	105 x 75–80	11	45
LH-POEV 160R	BH-POEV 160R	LH-POEV 160R-FI	160	50	400	roller bearing	202	140 x 110	105 x 75–80	11	65
LH-POEV 160KA	BH-POEV 160KA	LH-POEV 160KA-FI	160	50	400	ball bearing (CC)	202	140 x 110	105 x 75–80	11	65
LH-POEV 200R	BH-POEV 200R	LH-POEV 200R-FI	200	50	500	roller bearing	245	140 x 110	105 x 75–80	11	70
LH-POEV 200KA	BH-POEV 200KA	LH-POEV 200KA-FI	200	50	500	ball bearing (CC)	245	140 x 110	105 x 75–80	11	70
LH-POEV 250R	BH-POEV 250R	*	250	50	600	roller bearing	295	140 x 110	105 x 75–80	11	82
LH-POEV 250K	BH-POEV 250K	*	250	50	600	ball bearing	295	140 x 110	105 x 75–80	11	82

\* "stop-top" brake version, see versions / options

### Versions / options\*\*



	with non-marking grey tyre	with non-marking blue tyre	electrically conductive version, black tyre	with "stop-top" brake	with "central-stop" central brake system	with "ideal-stop" brake total height +17 mm	with steel foot guard
Technical description page	52	53	50	112	113	112	116
Product code suffix	-SG	-SB	-EL	-ST	-CS13	-IS	-FS
Available for	all wheel Ø 80–200 mm Ø 250 ball bearing only	wheel Ø 100–200 mm	ball bearing versions upon request	all	wheel Ø 160–200 mm	wheel Ø 160–200 mm***	upon request

\*\* Other versions / options: 1. pressed steel thread guard, zinc-plated (-FA), available for wheel Ø 100–250 mm upon request; 2. stainless steel wheel bearing or ball bearing seal: see versions / options page 212–213  
3. directional lock (separate) 1 x 360°: RI-04.01 for wheel Ø 80–125 mm with 100x85 mm plate, RI-05.03 for wheel Ø 160–200 mm (only for swivel castors without brake or swivel castor with "stop-top" and "central-stop" brake upon request)

\*\*\* Synthetic adapter plate to balance out total height for swivel and fixed castors without "ideal-stop" brake: product code AP3-17

## LUH-POEV, BH-POEV series

**Pressed steel castors, heavy-duty design, enclosed, with top plate, wheel with "Blickle EasyRoll" elastic solid rubber tyre**



400–500 kg

**Bracket:** LUH/BH series

- strong pressed steel, zinc-plated, blue-passivated, Cr6-free

**Swivel bracket:**

- four-point ball bearing for extremely heavy loads
- enclosed and sealed swivel head
- particularly resistant to shocks and impact due to specially-shaped, hardened bearing seats

**Wheel:** POEV series

- tyre: high-quality elastic solid rubber "Blickle EasyRoll" in smooth rolling quality, hardness 65 Shore A, colour black
- wheel centre: high-quality nylon 6, impact resistant, colour black

**Additional details:**

- bracket series: page 93
- brakes: page 112–113
- wheel series: page 212–213
- bearing types: page 84–85



3

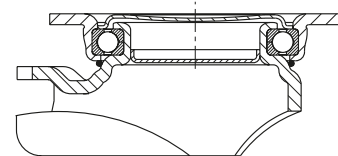

Swivel castors	Fixed castors	Swivel castors with "stop-fix" brake	Wheel Ø [mm]	Wheel width [mm]	Load capacity [kg]	Bearing type	Total height [mm]	Plate size [mm]	Bolt hole spacing [mm]	Bolt hole Ø [mm]	Offset swivel castor [mm]
LUH-POEV 160R	BH-POEV 160R	LUH-POEV 160R-FI	160	50	400	roller bearing	202	140 x 110	105 x 75–80	11	61
LUH-POEV 160KA	BH-POEV 160KA	LUH-POEV 160KA-FI	160	50	400	ball bearing (CC)	202	140 x 110	105 x 75–80	11	61
LUH-POEV 200R	BH-POEV 200R	LUH-POEV 200R-FI	200	50	500	roller bearing	245	140 x 110	105 x 75–80	11	63
LUH-POEV 200KA	BH-POEV 200KA	LUH-POEV 200KA-FI	200	50	500	ball bearing (CC)	245	140 x 110	105 x 75–80	11	63

### Versions / options \*



	with non-marking grey tyre	with non-marking blue tyre	electrically conductive version, black tyre	with thread guard, pressed steel, zinc-plated	directional lock (separate) 1 x 360°	with stainless steel roller bearing in the wheel hub	with steel foot guard
Technical description page	52	53	50	116	115	84	116
<b>Product code suffix</b>	<b>-SG</b>	<b>-SB</b>	<b>-EL</b>	<b>-FA</b>	<b>RI-05.03</b>	<b>-XR</b>	<b>-FS</b>
Available for	all	all	ball bearing versions upon request	all	all**	all	upon request

\* **Other versions / options:** 1. wheel with additional ball bearing seal (-KAD), available for all (see page 84 for technical information)  
 2. stainless steel ball bearing and thread guard, small (-XKA), available for all KA versions of -SG version, non-marking grey (see page 84 for technical information)  
 \*\* Only for swivel castors without brake

## ALEV series

Heavy-duty wheels with elastic solid rubber tyre  
 “Blickle EasyRoll”,  
 with aluminium wheel centre



200–650 kg

**Tread and tyre hardness**

65 Shore A

**Smooth operation / floor preservation**

very good

**Rolling resistance**

very good

**Wear resistance**

good



**Tyre:**

- high-quality elastic solid rubber “Blickle EasyRoll” in smooth rolling quality, hardness 65 Shore A
- very good operational comfort
- very good floor preservation, low-noise operation
- low rolling resistance
- colour black
- vulcanised onto the wheel centre

**Wheel centre:**

- die-cast aluminium

**Other features:**

- high chemical resistance to many aggressive substances, except oils
- operating temperature: -20 °C to +80 °C, temporarily up to +100 °C, reduced load capacity over +60 °C

Wheels	Wheel Ø (D) [mm]	Wheel width (T2) [mm]	Load capacity at 4 km/h [kg]	Load capacity at 10 km/h [kg]	Bearing type	Axle bore Ø (d) [mm]	Hub length (T1) [mm]
ALEV 100/15K	100	40	200	–	ball bearing	15	40
ALEV 125/15K	125	40	250	–	ball bearing	15	45
ALEV 127/20K	125	50	300	150	ball bearing	20	60
ALEV 140/20K	140	40	300	150	ball bearing	20	60
ALEV 150/20K	150	50	400	200	ball bearing	20	60
ALEV 161/15K	160	40	300	150	ball bearing	15	60
ALEV 160/20K	160	50	400	200	ball bearing	20	60
ALEV 160/25K	160	50	400	200	ball bearing	25	60
ALEV 180/20K	180	50	450	220	ball bearing	20	60
ALEV 180/25K	180	50	450	220	ball bearing	25	60
ALEV 200/20K	200	50	500	250	ball bearing	20	60
ALEV 200/25K	200	50	500	250	ball bearing	25	60
ALEV 250/20K	250	50	650	320	ball bearing	20	60
ALEV 250/25K	250	50	650	320	ball bearing	25	60

**Additional details:**

- wheel series: page 63
- tread: page 53
- bearing types: page 84–85
- chemical resistance: page 51

### Versions / options



	with non-marking grey tyre	antistatic version, non-marking, grey tyre	electrically conductive version, black tyre
Technical description page	52	53	50
<b>Product code suffix</b>	<b>-SG</b>	<b>-SG-AS</b>	<b>-EL</b>
Available for	all	wheel Ø 100, 125x40, 160x50, 200, 250 mm	wheel Ø 100, 125x40, 160, 200, 250 mm

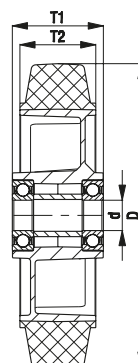

## L-ALEV, B-ALEV, BH-ALEV series

Pressed steel castors, medium-duty version, with top plate, wheel with "Blickle EasyRoll" elastic solid rubber tyres



200–500 kg

**Bracket:** L/B/BH series

- pressed steel, zinc-plated, blue-passivated, Cr6-free

**Swivel bracket:**

- double ball bearing in the swivel head
- strong central kingpin (from wheel Ø 150 mm)
- swivel head seal
- minimum swivel head play and smooth rolling characteristic and increased service life due to the special dynamic Blickle riveting process

**Wheel:** ALEV series

- tyre: high-quality elastic solid rubber "Blickle EasyRoll" in smooth rolling quality, hardness 65 Shore A, colour black
- wheel centre: die-cast aluminium

**Additional details:**

- bracket series: page 91
- brakes: page 112–113
- wheel series: page 221
- bearing types: page 84–85



3

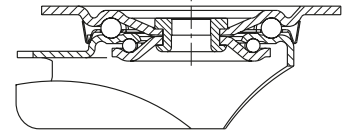

Swivel castors	Fixed castors	Swivel castors with "stop-fix" brake	Wheel Ø [mm]	Wheel width [mm]	Load capacity [kg]	Bearing type	Total height [mm]	Plate size [mm]	Bolt hole spacing [mm]	Bolt hole Ø [mm]	Offset swivel castor [mm]
L-ALEV 100K	B-ALEV 100K	L-ALEV 100K-FI	100	40	200	ball bearing	125	100 x 85	80 x 60	9	36
L-ALEV 125K	B-ALEV 125K	L-ALEV 125K-FI	125	40	250	ball bearing	150	100 x 85	80 x 60	9	38
L-ALEV 150K	B-ALEV 150K	L-ALEV 150K-FI	150	50	400	ball bearing	190	140 x 110	105 x 75–80	11	60
L-ALEV 161K	B-ALEV 161K	L-ALEV 161K-FI	160	40	300	ball bearing	195	140 x 110	105 x 75–80	11	60
L-ALEV 160K	B-ALEV 160K	L-ALEV 160K-FI	160	50	400	ball bearing	195	140 x 110	105 x 75–80	11	60
L-ALEV 180K	B-ALEV 180K	L-ALEV 180K-FI	180	50	400	ball bearing	215	140 x 110	105 x 75–80	11	60
L-ALEV 200K	B-ALEV 200K	L-ALEV 200K-FI	200	50	400	ball bearing	235	140 x 110	105 x 75–80	11	65
L-ALEV 250K-3	BH-ALEV 250K	*	250	50	500	ball bearing	295	140 x 110	105 x 75–80	11	77

\* "stop-top" brake version, see versions / options

### Versions / options



	with non-marking grey tyre	antistatic version, non-marking, grey tyre	electrically conductive version, black tyre	with "stop-top" brake	with "central-stop" central brake system	with directional lock (separate) 1x 360°	with steel foot guard
Technical description page	52	53	50	112	113	115	116
Product code suffix	-SG	-SG-AS	-EL	-ST	-CS11	see **	-FS
Available for	all	wheel Ø 100, 125x40, 160x50, 200, 250 mm	wheel Ø 100, 125, 160, 200, 250 mm	all	wheel Ø 160+200 mm	for wheel Ø and plate dimensions, see**	all

\*\* RI-03.01 for wheel Ø 100–125 mm, RI-05.03 for wheel Ø 150–200 mm (Only for swivel castors without brake or swivel castor with "stop-top" and "central-stop" brake upon request)



## LK-ALEV, BK-ALEV, BH-ALEV series

Pressed steel castors, heavy-duty design, with top plate, wheel with "Blickle EasyRoll" elastic solid rubber tyre



200–500 kg

**Bracket:** LK/BK/BH series

- strong pressed steel, zinc-plated, blue-passivated, Cr6-free

**Swivel bracket:**

- double ball bearing in the swivel head
- strong central kingpin (from wheel Ø 125x50 mm)
- swivel head seal
- minimum swivel head play and smooth rolling characteristic and increased service life due to the special dynamic Blickle riveting process

**Wheel:** ALEV series

- tyre: high-quality elastic solid rubber "Blickle EasyRoll" in smooth rolling quality, hardness 65 Shore A, colour black
- wheel centre: die-cast aluminium

**Additional details:**

- bracket series: page 92
- brakes: page 112–113
- wheel series: page 221
- bearing types: page 84–85



3

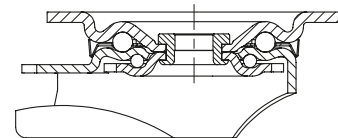

Swivel castors	Fixed castors	Swivel castors with "stop-fix" brake	Wheel Ø [mm]	Wheel width [mm]	Load capacity [kg]	Bearing type	Total height [mm]	Plate size [mm]	Bolt hole spacing [mm]	Bolt hole Ø [mm]	Offset swivel castor [mm]
LK-ALEV 100K-1	BK-ALEV 100K-1	LK-ALEV 100K-1-FI	100	40	200	ball bearing	130	100 x 85	80 x 60	9	45
LK-ALEV 100K-3	BK-ALEV 100K-3	LK-ALEV 100K-3-FI	100	40	200	ball bearing	130	140 x 110	105 x 75–80	11	45
LK-ALEV 125K-1	BK-ALEV 125K-1	LK-ALEV 125K-1-FI	125	40	250	ball bearing	155	100 x 85	80 x 60	9	48
LK-ALEV 125K-3	BK-ALEV 125K-3	LK-ALEV 125K-3-FI	125	40	250	ball bearing	155	140 x 110	105 x 75–80	11	48
LK-ALEV 127K	BH-ALEV 127K	LK-ALEV 127K-FI	125	50	300	ball bearing	170	140 x 110	105 x 75–80	11	55
LK-ALEV 150K	BH-ALEV 150K	LK-ALEV 150K-FI	150	50	400	ball bearing	197	140 x 110	105 x 75–80	11	60
LK-ALEV 160K	BH-ALEV 160K	LK-ALEV 160K-FI	160	50	400	ball bearing	202	140 x 110	105 x 75–80	11	60
LK-ALEV 180K	BH-ALEV 180K	LK-ALEV 180K-FI	180	50	450	ball bearing	223	140 x 110	105 x 75–80	11	65
LK-ALEV 200K	BH-ALEV 200K	LK-ALEV 200K-FI	200	50	500	ball bearing	245	140 x 110	105 x 75–80	11	62

### Versions / options \*



	with non-marking grey tyre	antistatic version, non-marking, grey tyre	electrically conductive version, black tyre	with "stop-top" brake	with "central-stop" central brake system	with "ideal-stop" brake total height +17 mm	with directional lock (separate) 1x 360°
Technical description page	52	53	50	112	113	112	115
Product code suffix	-SG	-SG-AS	-EL	-ST	-CS11	-IS	see ***
Available for	all	wheel Ø 100, 125x40, 160, 200, 250 mm	wheel Ø 100, 125x40, 160, 200 mm	all	wheel Ø 100–125x40 mm	wheel Ø 100, 125, 160, 200 mm with plate 140x110 mm**	for wheel Ø and plate dimensions, see***

\* Other versions / options: steel foot guard (-FS), available upon request

\*\* Synthetic adapter plate to balance out total height for swivel and fixed castors without "ideal-stop" brake: product code AP3-17

\*\*\* RI-05.01 for wheel Ø 100–125 mm with plate 100x85 mm, RI-03.03 for wheel Ø 100–125x40 mm with plate 140x110 mm, RI-05.03 for wheel Ø 125x50–200 mm (Only for swivel castors without brake or swivel castor with "stop-top" and "central-stop" brake upon request)

## LH-ALEV, BH-ALEV series

Pressed steel castors, heavy-duty design, with top plate, wheel with "Blickle EasyRoll" elastic solid rubber tyre

200–650 kg

**Bracket:** LH/BH series

- strong pressed steel, zinc-plated, blue-passivated, Cr6-free
- heavy fork and top plate

**Swivel bracket:**

- double ball bearing in the swivel head
- bolted and secured central kingpin, extremely strong
- particularly resistant to shocks and impact due to **four specially-shaped, hardened bearing seats**

**Wheel:** ALEV series

- tyre: high-quality elastic solid rubber "Blickle EasyRoll" in smooth rolling quality, hardness 65 Shore A, colour black
- wheel centre: die-cast aluminium

**Additional details:**

- bracket series: page 92
- brakes: page 112–113
- wheel series: page 221
- bearing types: page 84–85



3

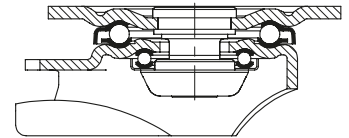

Swivel castors	Fixed castors	Swivel castors with "stop-fix" brake	Wheel Ø [mm]	Wheel width [mm]	Load capacity [kg]	Bearing type	Total height [mm]	Plate size [mm]	Bolt hole spacing [mm]	Bolt hole Ø [mm]	Offset swivel castor [mm]
LH-ALEV 100K-1	BH-ALEV 100K-1	LH-ALEV 100K-1-FI	100	40	200	ball bearing	140	100 x 85	80 x 60	9	45
LH-ALEV 100K-3	BH-ALEV 100K-3	LH-ALEV 100K-3-FI	100	40	200	ball bearing	140	140 x 110	105 x 75–80	11	45
LH-ALEV 125K-1	BH-ALEV 125K-1	LH-ALEV 125K-1-FI	125	40	250	ball bearing	165	100 x 85	80 x 60	9	45
LH-ALEV 125K-3	BH-ALEV 125K-3	LH-ALEV 125K-3-FI	125	40	250	ball bearing	165	140 x 110	105 x 75–80	11	45
LH-ALEV 127K	BH-ALEV 127K	LH-ALEV 127K-FI	125	50	300	ball bearing	170	140 x 110	105 x 75–80	11	55
LH-ALEV 150K	BH-ALEV 150K	LH-ALEV 150K-FI	150	50	400	ball bearing	197	140 x 110	105 x 75–80	11	65
LH-ALEV 160K	BH-ALEV 160K	LH-ALEV 160K-FI	160	50	400	ball bearing	202	140 x 110	105 x 75–80	11	65
LH-ALEV 180K	BH-ALEV 180K	LH-ALEV 180K-FI	180	50	450	ball bearing	223	140 x 110	105 x 75–80	11	67
LH-ALEV 200K	BH-ALEV 200K	LH-ALEV 200K-FI	200	50	500	ball bearing	245	140 x 110	105 x 75–80	11	70
LH-ALEV 250K	BH-ALEV 250K	*	250	50	650	ball bearing	295	140 x 110	105 x 75–80	11	82

\* "stop-top" brake version, see versions / options

### Versions / options\*\*



	with non-marking grey tyre	antistatic version, non-marking, grey tyre	electrically conductive version, black tyre	with "stop-top" brake	with "central-stop" central brake system	with "ideal-stop" brake total height +17 mm	with directional lock (separate) 1x 360°
Technical description page	52	53	50	112	113	112	115
Product code suffix	-SG	-SG-AS	-EL	-ST	-CS13	-IS	see ****
Available for	all	wheel Ø 100, 125x40, 160, 200, 250 mm	wheel Ø 100, 125x40, 160, 200, 250 mm	all	wheel Ø 160+200 mm	wheel Ø 160+200 mm***	for wheel Ø and plate dimensions, see****

\*\* Other versions / options: steel foot guard (-FS), available for all

\*\*\* Synthetic adapter plate to balance out total height for swivel and fixed castors without "ideal-stop" brake: **product code AP3-17**

\*\*\*\* **RI-04.01** for wheel Ø 100–125x40 mm with plate 100x85 mm, **RI-04.03** for wheel Ø 100–125x40 mm with plate 140x110 mm, **RI-05.03** for wheel Ø 125x50–200 mm (Only for swivel castors without brake or swivel castor with "stop-top" and "central-stop" brake upon request)

## LUH-ALEV, BH-ALEV series

**Pressed steel castors, heavy-duty design, enclosed, with top plate, wheel with "Blickle EasyRoll" elastic solid rubber tyre**

300–500 kg

**Bracket:** LUH/BH series

- strong pressed steel, zinc-plated, blue-passivated, Cr6-free

**Swivel bracket:**

- four-point ball bearing for extremely heavy loads
- enclosed and sealed swivel head
- particularly resistant to shocks and impact due to **specially-shaped, hardened bearing seats**

**Wheel:** ALEV series

- tyre: high-quality elastic solid rubber "Blickle EasyRoll" in smooth rolling quality, hardness 65 Shore A, colour black
- wheel centre: die-cast aluminium

**Additional details:**

- bracket series: page 93
- brakes: page 112–113
- wheel series: page 221
- bearing types: page 84–85

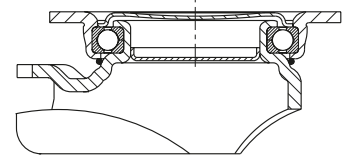

Swivel castors	Fixed castors	Swivel castors with "stop-fix" brake	Wheel Ø [mm]	Wheel width [mm]	Load capacity [kg]	Bearing type	Total height [mm]	Plate size [mm]	Bolt hole spacing [mm]	Bolt hole Ø [mm]	Offset swivel castor [mm]
LUH-ALEV 127K	BH-ALEV 127K	LUH-ALEV 127K-FI	125	50	300	ball bearing	170	140 x 110	105 x 75–80	11	55
LUH-ALEV 150K	BH-ALEV 150K	LUH-ALEV 150K-FI	150	50	400	ball bearing	197	140 x 110	105 x 75–80	11	61
LUH-ALEV 160K	BH-ALEV 160K	LUH-ALEV 160K-FI	160	50	400	ball bearing	202	140 x 110	105 x 75–80	11	61
LUH-ALEV 200K	BH-ALEV 200K	LUH-ALEV 200K-FI	200	50	500	ball bearing	245	140 x 110	105 x 75–80	11	63

### Versions / options



	with non-marking grey tyre	antistatic version, non-marking, grey tyre	electrically conductive version, black tyre	directional lock (separate) 1 x 360°	with steel foot guard
Technical description page	52	53	50	115	116
<b>Product code suffix</b>	<b>-SG</b>	<b>-SG-AS</b>	<b>-EL</b>	<b>RI-05.03</b>	<b>-FS</b>
Available for	all	wheel Ø 160–200 mm	wheel Ø 160–200 mm	all*	upon request

\* Only for swivel castors without brake

## LO-ALEV, BO-ALEV series

**Welded steel heavy-duty castors,  
wheel with "Blickle EasyRoll" elastic solid rubber tyre**

300–650 kg

**Bracket:** LO/BO series

- solid welded steel construction, zinc-plated, blue-passivated, Cr6-free

**Swivel bracket:**

- double ball bearing in the swivel head
- **four specially-shaped, hardened bearing seats** for additional strength
- bolted and secured welded central kingpin, extremely strong
- swivel head seal with labyrinth design
- grease nipple

**Wheel:** ALEV series

- tyre: high-quality elastic solid rubber "Blickle EasyRoll" in smooth rolling quality, hardness 65 Shore A, colour black
- wheel centre: die-cast aluminium

**Additional details:**

- bracket series: page 93
- brakes: page 112–113
- wheel series: page 221
- bearing types: page 84–85



3

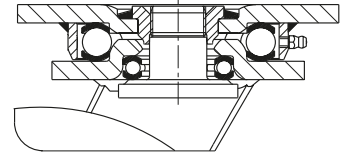

Swivel castors	Fixed castors	Swivel castor with "stop-top" brake	Wheel Ø [mm]	Wheel width [mm]	Load capacity [kg]	Bearing type	Total height [mm]	Plate size [mm]	Bolt hole spacing [mm]	Bolt hole Ø [mm]	Offset swivel castor [mm]
LO-ALEV 127K	BO-ALEV 127K	LO-ALEV 127K-ST	125	50	300	ball bearing	170	140 x 110	105 x 75–80	11	50
LO-ALEV 150K	BO-ALEV 150K	LO-ALEV 150K-ST	150	50	400	ball bearing	200	140 x 110	105 x 75–80	11	55
LO-ALEV 160K	BO-ALEV 160K	LO-ALEV 160K-ST	160	50	400	ball bearing	205	140 x 110	105 x 75–80	11	55
LO-ALEV 200K	BO-ALEV 200K	LO-ALEV 200K-ST	200	50	500	ball bearing	245	140 x 110	105 x 75–80	11	60
LO-ALEV 250K	BO-ALEV 250K	LO-ALEV 250K-ST	250	50	650	ball bearing	295	140 x 110	105 x 75–80	11	70

### Versions / options



	with non-marking grey tyre	antistatic version, non-marking, grey tyre	electrically conductive version, black tyre	with directional lock 4 x 90°	with steel foot guard	truck lock
Technical description page	52	53	50	115	116	114
Product code suffix	-SG	-SG-AS	-EL	-RI4	-FS	FF 125 / 150 / 160 / 200
Available for	all	wheel Ø 160–250 mm	wheel Ø 160–250 mm	wheel Ø 125–200 mm	upon request	wheel Ø 125–200 mm

## LHD-SE, BOD-SE, LHD-ALEV, BOD-ALEV series

**Pressed steel twin wheel castors, heavy-duty brackets, with top plate, wheel with "Blickle EasyRoll" elastic solid rubber tyre**

360–500 kg

**Bracket:** LHD/BOD series

- strong pressed steel, zinc-plated, blue-passivated, Cr6-free (fixed bracket: solid welded steel construction)
- heavy fork and top plate

**Swivel bracket:**

- double ball bearing in the swivel head
- bolted and secured central kingpin, extremely strong
- particularly resistant to shocks and impact due to **four specially-shaped, hardened bearing seats**

**Wheel:** ALEV/SE series

- tyre: high-quality elastic solid rubber "Blickle EasyRoll" in smooth rolling quality, hardness 65 Shore A, colour black
- wheel centre: ALEV series: die-cast aluminium series SE: high-quality nylon 6, impact resistant, black

**Additional details:**

- bracket series: page 93
- wheel series: page 221, 228
- bearing types: page 84–85



3

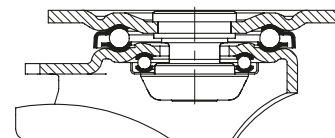

Swivel castors	Fixed castors	Wheel Ø [mm]	Wheel width [mm]	Load capacity [kg]	Bearing type	Total height [mm]	Plate size [mm]	Bolt hole spacing [mm]	Bolt hole Ø [mm]	Offset swivel castor [mm]
LHD-SE 80K	BOD-SE 80K	80	2 x 45	360	ball bearing	115	140 x 110	105 x 75–80	11	45
LHD-ALEV 100K	BOD-ALEV 100K	100	2 x 40	400	ball bearing	145	140 x 110	105 x 75–80	11	45
LHD-ALEV 125K	BOD-ALEV 125K	125	2 x 40	500	ball bearing	170	140 x 110	105 x 75–80	11	50

Fixed castors: long side of plate parallel to the wheel axle

### Versions / options



	with non-marking grey tyre	antistatic version, non-marking, grey tyre	electrically conductive version, black tyre
Technical description page	52	53	50
<b>Product code suffix</b>	<b>-SG</b>	<b>-SG-AS</b>	<b>-EL</b>
Available for	wheel Ø 100–125 mm	wheel Ø 100–125 mm	wheel Ø 100–125 mm

## SE series

Heavy-duty wheels with elastic solid rubber tyre  
 “Blickle EasyRoll”, with welded steel  
 wheel centre or nylon wheel centre



200–1,150 kg

**Tread and tyre hardness**  
 65 Shore A

**Smooth operation / floor preservation**  
 very good

**Rolling resistance**  
 very good

**Wear resistance**  
 good



3

- Tyre:**
- high-quality elastic solid rubber “Blickle EasyRoll” in smooth rolling quality, hardness 65 Shore A
  - very good operational comfort
  - very good floor preservation, low-noise operation
  - low rolling resistance
  - colour black
  - vulcanised onto the wheel centre or product code ...-Z: steel-wire reinforced and pressed-on

- Wheel centre:**
- thick-walled pressed steel, with tubular steel hub, triple welded
  - resistant to dirt, impact and shocks
  - lacquered, colour anthracite
  - wheel Ø 80–125 mm made from high-quality nylon 6, impact resistant, colour black

- Other features:**
- chemical resistance to many aggressive substances, except oils
  - operating temperature: -20 °C to +80 °C, temporarily up to +100 °C, reduced load capacity over +60 °C

- Additional details:**
- wheel series: page 63
  - tread: page 53
  - bearing types: page 84–85
  - chemical resistance: page 51

Wheels	Wheel Ø (D) [mm]	Wheel width (T2) [mm]	Load capacity at 4 km/h [kg]	Load capacity at 10 km/h [kg]	Bearing type	Axle bore Ø (d) [mm]	Hub length (T1) [mm]
SE 80/20K	80	45	200	–	ball bearing	20	45
SE 100/20K	100	45	270	–	ball bearing	20	45
SE 125/20K	125	53	320	180	ball bearing	20	60
SE 160/20K	160	50	450	250	ball bearing	20	60
SE 200/20K	200	50	600	350	ball bearing	20	60
SE 200/25K	200	50	600	350	ball bearing	25	60
SE 202/25K	200	80	850	500	ball bearing	25	90
SE 250/25K	250	60	850	500	ball bearing	25	70
SE 252/25K	250	80	1,000	600	ball bearing	25	90
SE 252/30K	250	80	1,000	600	ball bearing	30	90
SE 300/30K	300	75	1,000	650	ball bearing	30	85
SE 360/30K-Z	360	75	950	760	ball bearing	30	90
SE 400/35K-Z	400	65	900	720	ball bearing	35	75
SE 415/35K-Z	415	90	1,150	920	ball bearing	35	100

For other dimensions, see wheel series GEV on page 234

### Versions / options



	with non-marking grey tyre	with grease nipple
Technical description page	52	
<b>Product code suffix</b>	<b>-SG</b>	<b>-NI</b>
Available for	wheel Ø 125–200 mm, others upon request	wheel Ø 200–415 mm upon request

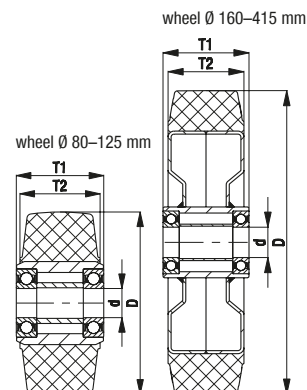

## LK-SE, BK-SE, BH-SE series

Pressed steel castors, heavy-duty design, with top plate, wheel with "Blickle EasyRoll" elastic solid rubber tyre



200–600 kg

**Bracket:** LK/BK/BH series

- strong pressed steel, zinc-plated, blue-passivated, Cr6-free

**Swivel bracket:**

- double ball bearing in the swivel head
- strong central kingpin (from wheel Ø 125x50 mm)
- swivel head seal
- minimum swivel head play and smooth rolling characteristic and increased service life due to the special dynamic Blickle riveting process

**Wheel:** SE series

- tyre: high-quality elastic solid rubber "Blickle EasyRoll" in smooth rolling quality, hardness 65 Shore A, colour black
- wheel centre: thick-walled pressed steel, with tubular steel hub, lacquered, colour anthracite. wheel Ø 80–125 mm made from high-quality nylon 6, impact resistant, colour black

**Additional details:**

- bracket series: page 92
- brakes: page 112–113
- wheel series: page 228
- bearing types: page 84–85

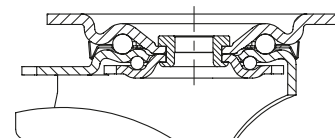

Swivel castors	Fixed castors	Swivel castors with "stop-fix" brake	Wheel Ø [mm]	Wheel width [mm]	Load capacity [kg]	Bearing type	Total height [mm]	Plate size [mm]	Bolt hole spacing [mm]	Bolt hole Ø [mm]	Offset swivel castor [mm]
LK-SE 80K	BK-SE 80K	LK-SE 80K-FI	80	45	200	ball bearing	110	100 x 85	80 x 60	9	40
LK-SE 100K-1	BK-SE 100K-1	LK-SE 100K-1-FI	100	45	270	ball bearing	130	100 x 85	80 x 60	9	45
LK-SE 100K-3	BK-SE 100K-3	LK-SE 100K-3-FI	100	45	270	ball bearing	130	140 x 110	105 x 75–80	11	45
LK-SE 125K	BH-SE 125K	LK-SE 125K-FI	125	53	320	ball bearing	170	140 x 110	105 x 75–80	11	55
LK-SE 160K	BH-SE 160K	LK-SE 160K-FI	160	50	450	ball bearing	202	140 x 110	105 x 75–80	11	60
LK-SE 200K	BH-SE 200K	LK-SE 200K-FI	200	50	600	ball bearing	245	140 x 110	105 x 75–80	11	62

### Versions / options



	with non-marking grey tyre	with "stop-top" brake	directional lock (separate) 1 x 360°	directional lock (separate) 1 x 360°	directional lock (separate) 1 x 360°	with steel foot guard
Technical description page	52	112	115	115	115	116
<b>Product code suffix</b>	<b>-SG</b>	<b>-ST</b>	<b>RI-05.01</b>	<b>RI-03.03</b>	<b>RI-05.03</b>	<b>-FS</b>
Available for	wheel Ø 125–200 mm, others upon request	all	wheel Ø 80–100 mm with plate 100x85 mm*	wheel Ø 100 mm with plate 140x110 mm*	wheel Ø 125–200 mm*	upon request

\* Only for swivel castors without brake or swivel castor with "stop-top" brake upon request

## LH-SE, BH-SE series

Pressed steel castors, heavy-duty design, with top plate, wheel with "Blickle EasyRoll" elastic solid rubber tyre

200–850 kg

**Bracket:** LH/BH series

- strong pressed steel, zinc-plated, blue-passivated, Cr6-free
- heavy fork and top plate

**Swivel bracket:**

- double ball bearing in the swivel head
- bolted and secured central kingpin, extremely strong
- particularly resistant to shocks and impact due to **four specially-shaped, hardened bearing seats**

**Wheel:** SE series

- tyre: high-quality elastic solid rubber "Blickle EasyRoll" in smooth rolling quality, hardness 65 Shore A, colour black
- wheel centre: thick-walled pressed steel, with tubular steel hub, lacquered, colour anthracite. wheel Ø 80–125 mm made from high-quality nylon 6, impact resistant, colour black

**Additional details:**

- bracket series: page 92
- brakes: page 112–113
- wheel series: page 228
- bearing types: page 84–85



3

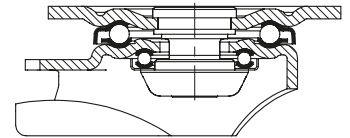

Swivel castors	Fixed castors	Swivel castors with "stop-fix" brake	Wheel Ø [mm]	Wheel width [mm]	Load capacity [kg]	Bearing type	Total height [mm]	Plate size [mm]	Bolt hole spacing [mm]	Bolt hole Ø [mm]	Offset swivel castor [mm]
LH-SE 80K	BH-SE 80K	LH-SE 80K-FI	80	45	200	ball bearing	120	100 x 85	80 x 60	9	45
LH-SE 100K-1	BH-SE 100K-1	LH-SE 100K-1-FI	100	45	270	ball bearing	140	100 x 85	80 x 60	9	45
LH-SE 100K-3	BH-SE 100K-3	LH-SE 100K-3-FI	100	45	270	ball bearing	140	140 x 110	105 x 75–80	11	45
LH-SE 125K	BH-SE 125K	LH-SE 125K-FI	125	53	320	ball bearing	170	140 x 110	105 x 75–80	11	55
LH-SE 160K	BH-SE 160K	LH-SE 160K-FI	160	50	450	ball bearing	202	140 x 110	105 x 75–80	11	65
LH-SE 200K	BH-SE 200K	LH-SE 200K-FI	200	50	600	ball bearing	245	140 x 110	105 x 75–80	11	70
LH-SE 202K	BO-SE 202K *	**	200	80	800	ball bearing	245	140 x 110	105 x 75–80	11	70
LH-SE 250K	BH-SE 250K	**	250	60	850	ball bearing	295	140 x 110	105 x 75–80	11	82

\* Welded steel construction

\*\* "stop-top" brake version, see versions / options

### Versions / options



	with non-marking grey tyre	with "stop-top" brake	with "central-stop" central brake system	with "ideal-stop" brake total height +17 mm	with directional lock (separate) 1x 360°	with steel foot guard	truck lock
Technical description page	52	112	113	112	115	116	114
<b>Product code suffix</b>	<b>-SG</b>	<b>-ST</b>	<b>-CS13</b>	<b>-IS</b>	<b>see ****</b>	<b>-FS</b>	<b>FF 125 / 160 / 200</b>
Available for	wheel Ø 125–200 mm, others upon request	all	wheel Ø 160–200x50 mm	wheel Ø 160–200 mm****	for wheel Ø and plate dimensions, see****	wheel Ø 100–250 mm	wheel Ø 125–200 mm

\*\*\* Synthetic adapter plate to balance out total height for swivel and fixed castors without "ideal-stop" brake: **product code AP3-17**

\*\*\*\* **RI-04.01** for wheel Ø 80–100 mm with plate 100x85 mm, **RI-04.03** for wheel Ø 100 mm with plate 140x110 mm, **RI-05.03** for wheel Ø 125–200x50 mm (Only for swivel castors without brake or swivel castor with "stop-top" and "central-stop" brake upon request)



## LO-SE, BO-SE series

**Welded steel heavy-duty castors, wheel with "Blickle EasyRoll" elastic solid rubber tyre**



320–850 kg

**Bracket:** LO/BO series

- solid welded steel construction, zinc-plated, blue-passivated, Cr6-free

**Swivel bracket:**

- double ball bearing in the swivel head
- **four specially-shaped, hardened bearing seats** for additional strength
- bolted and secured welded central kingpin, extremely strong
- swivel head seal with labyrinth design
- grease nipple

**Wheel:** SE series

- tyre: high-quality elastic solid rubber "Blickle EasyRoll" in smooth rolling quality, hardness 65 Shore A, colour black
- wheel centre: thick-walled pressed steel, with tubular steel hub, lacquered, colour black. wheel Ø 125 mm made from high-quality nylon 6, impact resistant, colour black

**Additional details:**

- bracket series: page 93
- brakes: page 112–113
- wheel series: page 228
- bearing types: page 84–85



**3**

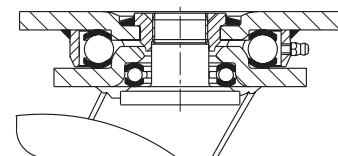

Swivel castors	Fixed castors	Swivel castor with "stop-top" brake	Wheel Ø [mm]	Wheel width [mm]	Load capacity [kg]	Bearing type	Total height [mm]	Plate size [mm]	Bolt hole spacing [mm]	Bolt hole Ø [mm]	Offset swivel castor [mm]
LO-SE 125K	BO-SE 125K	LO-SE 125K-ST	125	53	320	ball bearing	170	140 x 110	105 x 75–80	11	50
LO-SE 160K	BO-SE 160K	LO-SE 160K-ST	160	50	450	ball bearing	205	140 x 110	105 x 75–80	11	55
LO-SE 200K	BO-SE 200K	LO-SE 200K-ST	200	50	600	ball bearing	245	140 x 110	105 x 75–80	11	60
LO-SE 202K	BO-SE 202K	LO-SE 202K-ST	200	80	850	ball bearing	245	140 x 110	105 x 75–80	11	65
LO-SE 250K	BO-SE 250K	LO-SE 250K-ST	250	60	850	ball bearing	295	140 x 110	105 x 75–80	11	70

### Versions / options



	with non-marking grey tyre	with directional lock 4 x 90°	with steel foot guard	truck lock
Technical description page	52	115	116	114
<b>Product code suffix</b>	<b>-SG</b>	<b>-RI4</b>	<b>-FS</b>	<b>FF 125 / 160 / 200</b>
Available for	wheel Ø 125–200 mm, others upon request	wheel Ø 125–200x50 mm	upon request	wheel Ø 125–200 mm

## LS-SE, BS-SE series

### Welded steel heavy-duty castors, heavy-duty swivel head, wheel with "Blickle EasyRoll" elastic solid rubber tyres

320–1,150 kg

**Bracket:** LS/BS series

- particularly robust welded steel construction, zinc-plated, yellow-passivated, Cr6-free

**Swivel bracket:**

- axial grooved ball bearing ISO 104 and tapered roller bearing ISO 355 in the swivel head
- bolted and secured welded central kingpin, extremely strong
- dust and splash-proof
- grease nipple

**Wheel:** SE series

- tyre: high-quality elastic solid rubber "Blickle EasyRoll" in smooth rolling quality, hardness 65 Shore A, colour black
- wheel centre: thick-walled pressed steel, lacquered, colour anthracite. wheel Ø 125 mm made from high-quality nylon 6, impact resistant, colour black

**Additional details:**

- bracket series: page 94
- brakes: page 112–113
- wheel series: page 228
- bearing types: page 84–85



3

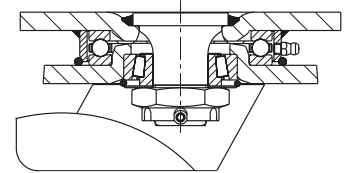

Swivel castors	Fixed castors	Swivel castor with "stop-top" brake	Wheel Ø [mm]	Wheel width [mm]	Load capacity [kg]	Bearing type	Total height [mm]	Plate size [mm]	Bolt hole spacing [mm]	Bolt hole Ø [mm]	Offset swivel castor [mm]
LS-SE 125K	BS-SE 125K	LS-SE 125K-ST	125	53	320	ball bearing	170	140 x 110	105 x 75–80	11	50
LS-SE 160K	BS-SE 160K	LS-SE 160K-ST	160	50	450	ball bearing	205	140 x 110	105 x 75–80	11	55
LS-SE 200K	BS-SE 200K	LS-SE 200K-ST	200	50	600	ball bearing	245	140 x 110	105 x 75–80	11	60
LS-SE 202K	BS-SE 202K	LS-SE 202K-ST	200	80	850	ball bearing	255	175 x 140	140 x 105	14	65
LS-SE 250K	BS-SE 250K	LS-SE 250K-ST	250	60	850	ball bearing	305	175 x 140	140 x 105	14	75
LS-SE 252K	BS-SE 252K	LS-SE 252K-ST	250	80	1,000	ball bearing	305	175 x 140	140 x 105	14	75
LS-SE 300K	BS-SE 300K	LS-SE 300K-ST	300	75	1,000	ball bearing	355	175 x 140	140 x 105	14	85
LS-SE 360K-Z	BS-SE 360K-Z		360	75	950	ball bearing	420	175 x 140	140 x 105	14	85
LS-SE 415K-Z	BS-SE 415K-Z		415	90	1,150	ball bearing	478	200 x 160	160 x 120	14	100

### Versions / options



	with non-marking grey tyre	with "Radstop" wheel brake	with directional lock 4 x 90°	with steel foot guard	truck lock
Technical description page	52	113	115	116	114
<b>Product code suffix</b>	<b>-SG</b>	<b>-RA</b>	<b>-RI4</b>	<b>-FS</b>	<b>FF 125 / 160 / 200</b>
Available for	wheel Ø 125–200 mm, others upon request	wheel Ø 360–415 mm upon request	all	up to wheel Ø 250 mm	wheel Ø 125–200x50 mm

## LSD-SE, BSD-SE series

**Welded steel heavy-duty twin wheel castors, heavy-duty swivel head, wheels with "Blickle EasyRoll" elastic solid rubber tyres**



900–2,000 kg

**Bracket:** LSD/BSL series

- particularly robust welded steel construction, zinc-plated, yellow-passivated, Cr6-free
- Swivel bracket:
  - axial grooved ball bearing ISO 104 and tapered roller bearing ISO 355 in the swivel head
  - bolted and secured welded central kingpin, extremely strong
  - dust and splash-proof
  - grease nipple

**Wheel:**SE series

- tyre: high-quality elastic solid rubber "Blickle EasyRoll" in smooth rolling quality, hardness 65 Shore A, colour black
- wheel centre: thick-walled pressed steel, with tubular steel hub, lacquered, colour anthracite

**Additional details:**

- bracket series: page 94
- brakes: page 112–113
- wheel series: page 228
- bearing types: page 84–85

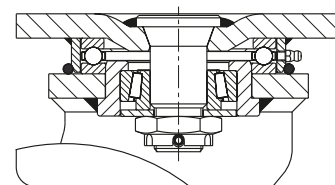

Swivel castors	Fixed castors	Wheel Ø [mm]	Wheel width [mm]	Load capacity [kg]	Bearing type	Total height [mm]	Plate size [mm]	Bolt hole spacing [mm]	Bolt hole Ø [mm]	Offset swivel castor [mm]
LSD-SE 160K-35	BSD-SE 160K-35	160	2 x 50	900	ball bearing	220	175 x 140	140 x 105	14	55
LSD-SE 200K-35	BSD-SE 200K-35	200	2 x 50	1,200	ball bearing	260	175 x 140	140 x 105	14	60
LSD-SE 250K	BSD-SE 250K	250	2 x 60	1,700	ball bearing	330	255 x 200	210 x 160	18	70
LSD-SE 300K	BSD-SE 300K	300	2 x 75	2,000	ball bearing	380	255 x 200	210 x 160	18	80

Fixed castors: long side of plate parallel to the wheel axle

### Versions / options



	with non-marking grey tyre	with "Radstop" wheel brake	with "Radstop" wheel brake	with directional lock 4 x 90°	with directional lock 4 x 90° (inserted by hand)	with steel foot guard
Technical description page	52	113	113	115	115	116
Product code suffix	<b>-SG</b>	<b>-RA</b>	<b>-RAH</b>	<b>-RI4</b>	<b>-RI4H</b>	<b>-FS</b>
Available for	wheel Ø 160–200 mm, others upon request	wheel Ø 160–200 mm upon request	wheel Ø 250–300 mm upon request	wheel Ø 160–200 mm upon request	wheel Ø 250–300 mm upon request	upon request

## GEV series

Heavy-duty wheels with elastic solid rubber tyres,  
with cast iron wheel centre



870–4,540 kg

**Tread and tyre hardness**



65 Shore A

**Smooth operation / floor preservation**



very good

**Rolling resistance**



very good

**Wear resistance**



good

3

**Tyre:**

- high-quality elastic solid rubber in smooth rolling quality, steel-wire reinforced, hardness 65 Shore A
- very good operational comfort
- very good floor preservation, low-noise operation
- low rolling resistance
- colour black

**Wheel centre:**

- rugged grey cast iron
- with grease nipple
- lacquered, colour anthracite

**Other features:**

- chemical resistance to many aggressive substances, except oils
- operating temperature: -20 °C to +80 °C, temporarily up to +100 °C, reduced load capacity over +60 °C
- wheel centre is approximately 4 mm wider than the specified wheel width

**Additional details:**

- wheel series: page 63
- tread: page 53
- bearing types: page 84–85
- chemical resistance: page 51

Wheels	Wheel Ø	Wheel width	Load capacity at 4 km/h	Load capacity at 10 km/h	Load capacity at 16 km/h	Bearing type	Axle bore Ø	Hub length
	(D) [mm]	(T2) [mm]	[kg]	[kg]	[kg]		(d) [mm]	(T1) [mm]
GEV 254/30K	250	130	1,270	875	800	ball bearing	30	130
GEV 280/25K	280	75	870	580	440	ball bearing	25	90
GEV 302/35K	300	90	1,080	720	540	ball bearing	35	90
GEV 360/30K	360	60	900	600	450	ball bearing	30	75
GEV 362/35K	360	75	1,140	760	570	ball bearing	35	90
GEV 400/30K	400	75	1,200	800	600	ball bearing	30	90
GEV 405/45K	405	130	1,800	1,200	900	ball bearing	45	130
GEV 425/45K	425	150	2,160	1,450	1,100	ball bearing	45	150
GEV 500/35K	500	85	1,560	1,050	780	ball bearing	35	90
GEV 520/40K	520	100	1,830	1,225	920	ball bearing	40	100
GEV 550/60K	550	160	2,700	1,800	1,350	ball bearing	60	160
GEV 610/60K	610	150	2,700	1,800	1,350	ball bearing	60	150
GEV 620/65K	620	200	4,540	3,105	2,835	ball bearing	65	200

Other dimensions available upon request

### Versions / options



	with non-marking natural colour tyre	wheel with hub cap (end wheel)	drive wheels with hub keyway	hub fitting wheels
Technical description page	53	117	542	552
Product code suffix	-SN	-E	GEVN series	GEVA series
Available for	upon request	upon request	see page 540	see page 550

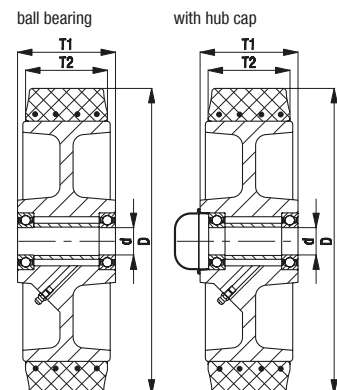

## LS-GEV, BS-GEV series

**Welded steel heavy-duty castors,  
heavy-duty swivel head,  
wheel with elastic solid rubber tyres**

1,080–4,540 kg

**Bracket:** LS/BS series

- particularly robust welded steel construction, zinc-plated, yellow-passivated, Cr6-free

**Swivel bracket:**

- axial grooved ball bearing ISO 104 and tapered roller bearing ISO 355 in the swivel head
- bolted and secured welded central kingpin, extremely strong
- dust and splash-proof
- grease nipple

**Wheel:** GEV series

- tyre: high-quality elastic solid rubber in smooth rolling quality, hardness 65 Shore A, colour black
- wheel centre: rugged grey cast iron, with grease nipple, lacquered, colour anthracite

**Additional details:**

- bracket series: page 94
- brakes: page 112–113
- wheel series: page 234
- bearing types: page 84–85

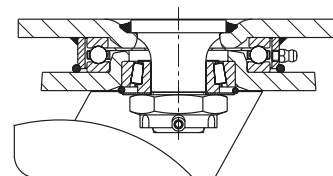

Swivel castors	Fixed castors	Wheel Ø [mm]	Wheel width [mm]	Load capacity [kg]	Bearing type	Total height [mm]	Plate size [mm]	Bolt hole spacing [mm]	Bolt hole Ø [mm]	Offset swivel castor [mm]
LS-GEV 302K	BS-GEV 302K	300	90	1,080	ball bearing	355	200 x 160	160 x 120	14	85
LS-GEV 400K	BS-GEV 400K	400	75	1,200	ball bearing	470	200 x 160	160 x 120	14	100
LS-GEV 520K	BS-GEV 520K	520	100	1,830	ball bearing	580	200 x 160	160 x 120	14	125
LS-GEV 620K		620	200	4,540	ball bearing	710	255 x 200	210 x 160	18	130
	BS-GEV 620K	620	200	4,540	ball bearing	710	250 x 270	210 x 160	18	–

### Versions / options



	with "stop-top" brake	with directional lock 4 x 90°	with "Radstop" wheel brake	with "Radstop" wheel brake	with directional lock 4 x 90° (inserted by hand)
Technical description page	112	115	113	113	115
<b>Product code suffix</b>	<b>-ST</b>	<b>-RI4</b>	<b>-RA</b>	<b>-RAH</b>	<b>-RI4H</b>
Available for	wheel Ø 300 mm	wheel Ø 300–520 mm	upon request	upon request	upon request

## DS series

**Heavy-duty twin wheels with elastic solid rubber tyres, with welded steel wheel centre, heavy-duty version**



1,800–4,580 kg

**Tread and tyre hardness**

65 Shore A

**Smooth operation / floor preservation**

very good

**Rolling resistance**

very good

**Wear resistance**

good

3

**Tyre:**

- high-quality elastic solid rubber in smooth rolling quality, steel-wire reinforced, hardness 65 Shore A
- very good operational comfort
- very good floor preservation, low-noise operation
- low rolling resistance
- colour black

**Wheel centre:**

- very strong welded steel construction
- with twice-welded tubular steel hub
- with grease nipple
- lacquered, colour anthracite

**Other features:**

- chemical resistance to many aggressive substances, except oils
- operating temperature: -20 °C to +80 °C, temporarily up to +100 °C, reduced load capacity over +60 °C
- wheel centre is approximately 4 mm wider than the specified wheel width

**Additional details:**

- wheel series: page 64
- tread: page 53
- bearing types: page 84–85
- chemical resistance: page 51

Wheels	Wheel Ø	Wheel width	Load capacity at 4 km/h	Load capacity at 10 km/h	Load capacity at 16 km/h	Bearing type	Axle bore Ø	Hub length
	(D) [mm]	(T2) [mm]	[kg]	[kg]	[kg]		(d) [mm]	(T1) [mm]
<b>DS 300/50K</b>	300	2 x 75	1,800	1,200	900	ball bearing	50	150
<b>DS 361/50K</b>	360	2 x 75	2,280	1,520	1,140	ball bearing	50	150
<b>DS 400/55K</b>	400	2 x 75	2,400	1,600	1,200	ball bearing	55	150
<b>DS 405/75K</b>	405	2 x 130	3,600	2,400	1,800	ball bearing	75	250
<b>DS 425/80K</b>	425	2 x 150	4,580	3,040	2,860	ball bearing	80	250
<b>DS 500/60K</b>	500	2 x 85	3,120	2,100	1,560	ball bearing	60	170

Other dimensions available upon request

### Versions / options



wheel with hub cap (end wheel)	drive wheel with hub keyway
--------------------------------	-----------------------------

Technical description page	117	
Product code suffix	-E	DSN series
Available for	upon request	upon request

